

ONSTED COMMUNITY SCHOOLS
BOARD OF EDUCATION
BOARD OF EDUCATION CONFERENCE ROOM
December 16, 2024

7:00 P.M.

PLEDGE OF ALLEGIANCE

CALL TO ORDER

Jason Terakedis, President

APPROVAL OF AGENDA

APPROVAL OF MINUTES

November 18, 2024 Regular Meeting Minutes

APPROVAL OF DISBURSEMENTS

STUDENT REPRESENTATIVE REPORT

COMMENTS FROM THE AUDIENCE

REPORTS

Student of the Month, Social Media Update

High School Building Report, Inclusion

Champions, Reproductive Health Advisory Board Update

EMPLOYMENT

24-25 #18

Hire: Austin Griffith - FT Custodian

Kimberly Samson - HS Science Teacher

24-25# 19

Separation: Caitlin Peterson - Bus Driver

DISCUSSION

24-25#20

District Facility Usage/Fee Schedule Policy Update

24-25# 21

Superintendent mid-year Evaluation Review

ACTION

24-25#22

Oven Purchase

COMMITTEE REPORTS

SUPERINTENDENT'S REPORT - Acknowledgement of Board Members, Victory Custom
Apparel Disclosure, Student Count

BOARD COMMENTS

EXECUTIVE SESSION

Superintendent mid-year Evaluation Review

ADJOURNMENT

MINUTES

ONSTED COMMUNITY SCHOOLS
BOARD OF EDUCATION MEETING

November 18, 2024

Meeting called to order at 7:00 p.m. by President Jason Terakedis

Members Present: R.Reynolds, R.Tessier, J.Terakedis, A.Gast, D.Vanbrunt, K.Williams

Members Absent: H.Ruttkofsky

Others Present: C.McMichael, M.Francis, C.Garrison, C.Garrett

The Pledge of Allegiance was led by President Terakedis.

Motion by A.Gast to approve the agenda with the addition of the middle school building report .
Seconded by D.Vanbrunt. Motion Carried 6-0 .

Motion by R.Reynolds to approve the minutes of the October 21st, 2024 BOE meeting.
Seconded by R.Tessier. Motion carried 6-0.

Motion by A.Gast to approve the disbursements for the month of October 2024 in the amount of \$1,206,183.17. There is an approximately \$2470 overage on charges related to a school credit card being compromised and having fraudulently been used. The board will see the reversal in the future. Seconded by R.Reynolds. Motion Carried 6-0.

The Student Representative report was read by Addison Gudakunst

Comments from the Audience:C.McMichael spoke regarding the coffee time with the superintendent. It was well received with 17 parents. Would like to see more coffee times happen.

Reports - Student of the Month report for each building was read. A.Ellison gave the MS building report. A.Ellison thanked the board for allowing her the time to be gone. A.Howland gave a presentation on Onsted On the Go.

Motion by R.Tessier to recognize the hiring of Rhonda Erhart - MS Paraprofessional. Seconded by R.Reynolds. Motion Carried 6-0.

Motion byD.VanBrunt to recognize the separation/resignations of Jamie Lewis - Head Cook, Kaylee Williams - Float Custodian, Teresa Tuttle - FT Custodian. Seconded by A.Gast. Motion Carried 6-0.

Motion by R.Reynolds to approve the NEOLA Policies Fall Update listed below. Seconded by R.Tessier. Motion Carried 6-0.

po2266	po5517	po1120	po3110
po4110	po6110	po6111	po6112
po6114	po6325	po6550	po7310
po7450	po3120.08	po5330.02	po5340
po5500	po7440.03	po7540.09	po8321

Motion by A.Gast to approve the 2023-2024 Financial Audit. Seconded by K.Williams. Motion Carried 6-0.

Committee Report - Financial Committee met November 18, 2024 to discuss the 23-24 financial audit which was covered in detail.

Superintendent's Report - Facilities and Custodial - open position, resurface gym floor, Set Seg insurance, Bishop Building winterized, tennis courts shut down
Food Service - open position, audit complete
Transportation - open position
Safety - fire drills completed, visitors should be wearing badges, Ok to Say is visiting this week.
Technology - looking at PA systems, desktops for teacher carts, replacement schedule for clocks and chromebooks
Business - audit complete
Curriculum - handbook created state-testing prep
Athletics - winter team meeting
First Coffee and Tea with the Supe - 16 attendees
BOE Results - Craig McMichael and Calby Garrison
The official declaration of the new Board of Education is still being processed. The county clerk hopes to have everything certified. With early voting, a lot more information was added to confirm and certify. Once they have the school candidates certified, they will mail the newly elected board members their Certificate of Election and a copy of the Acceptance of Office/Oath of Office.

Board Comments -
R.Reynolds - Band Glow
D.VanBrunt - Enjoyed Allison's report
J.Terakedis - Thanks to everyone - spoke on the water issue
R.Tessier - Congrats to Calby and Craig. Spoke on Lenawee United Hockey - more Onsted kids than anyone
A.Gast - Congrats to Calby and Craig, Congrats to XC winners, thanks to A.Ellison, A.Strong and A.Howland
K.Williams - Kudos to Anita and Jon for the audit. Welcome to Calby and Craig.

Motion by A.Gast to adjourn the meeting. Seconded by D.Vanbrunt. Meeting adjourned at 8:22pm.

David VanBrunt, Secretary
Board of Education
DVB:nlr

DISBURSEMENTS

Account	Description	Budget	Actual to 11-30-24
Total Local Revenue		2,962,113.00	113,021.36
Total State Revenue		13,295,018.00	885,714.99
Total Federal Revenue		579,000.00	454,827.00
Total Transfers & Other		955,674.00	6,350.00
		-----	-----
	Total Revenue.....	17,791,805.00	1,459,913.35
		-----	-----
Total Basic Instruction		8,476,500.00	2,057,490.65
Total Added Needs		2,894,298.00	727,017.94
Total Support Service-Pupil		1,004,598.00	239,754.20
Total Support Service-Instruction		225,954.00	60,823.21
Total Support Service-General		494,165.00	208,109.22
Total Support Service-School		869,825.00	298,330.49
Total Support Service-Business		261,825.00	125,326.27
Total Support Service-Oper. & Maint.		1,951,964.00	688,317.27
Total Support Service-Transportation		684,622.00	259,549.37
Total Support Service-Central		237,300.00	89,865.35
Total Support Service-Athletic		532,465.00	175,750.06
Total Community Service		110,000.00	47,039.98
Prior Period Adjustments		25,000.00	2,664.08
Total Transfers & Other		215,000.00	219,468.00
	Total Expense.....	-----	-----
		17,983,516.00	4,980,038.09
		-----	-----
Excess of Revenues over Disbursements		-191,711.00	-3,520,124.74
Fund Balances.....AUDITED		3,415,487.00	3,415,487.00
		-----	-----
Fund Balances November 30, 2024.....		3,223,776.00	-104,637.74

Disbursements for November:

Bank Michigan GF account	126,672.25
Electronic payments	1,036,164.40
Athletic account	19,036.56
Total	<u>1,181,873.21</u>

Cash balances per balance sheet:

Cash (general fund checking)	405,713.43
Petty cash	100.00
Payroll cash - Premier Bank	4,246.85
Cash Premier Bank Investment Acct.	1,121,781.96
Cash MiClass (GF)	1,413.40
Total cash	<u>1,533,255.64</u>



Check Register

Onsted Community Schools

Bank Account BM GF, From 11/01/2024 to 11/30/2024

Check #	Date	Run	Vendor	Name	Invoice Description	Amount
199455	11/05/2024	2	000210	ADRIAN MECHANICAL SERVICES CO.	WATER VALVE REPLACEMENT HIGH SCHOOL	4,102.00
199456	11/05/2024	2	001660	CONSUMERS ENERGY	GAS EXPENSE MS GAS EXPENSE HS/ELEM GAS EXPENSE ELEM	361.66+ 1,355.31+ 218.08+
Check Total						1,935.05=
199457	11/05/2024	2	011409	D & P COMMUNICATIONS, INC.	PHONE SERVICE	1,257.18
199458	11/05/2024	2	003125	FRAME'S PEST CONTROL	PEST CONTROL/YELLOW JACKETS PEST CONTROL PEST CONTROL	75.00+ 96.98+ 96.98+
Check Total						268.96=
199459	11/05/2024	2	001573	MICHIGAN FARM BUREAU	SCIENCE PROGRAMS	1,250.00
199460	11/05/2024	2	007337	TRACY INC.	USER LIC.	1,020.00
199461	11/06/2024	2	001575	FARLEY, JESSE	GSRP LITERACY NIGHT	60.00
199462	11/06/2024	2	001151	LYONS LP GAS CO. INC	FUEL FUEL FUEL	621.13+ 473.75+ 632.24+
Check Total						1,727.12=
199466	11/11/2024	800	002296	BLACKROCK COLLEGE ADVANTAGE 529	2024/2025 / 10 COL529 - PUTNAM 529 COLLEG.	200.00
199467	11/11/2024	800	003872	LENAWEE CARES	2024/2025 / 10 UNWAY - UNITED WAY	137.00
199468	11/11/2024	800	008565	TRUSTMARK VOLUNTARY BENEFIT SOL	2024/2025 / 10 BEN-LIFE - BENEFITS FOR LIFE ..	290.49
199469	11/19/2024	2	000210	ADRIAN MECHANICAL SERVICES CO.	BOILER LEAKING	884.30
199470	11/19/2024	2	001480	ADRIAN OVERHEAD DOORS	CABLE REPAIR	125.00
199471	11/19/2024	2	010357	A PARTS WAREHOUSE	PARTS	135.24
199472	11/19/2024	2	000044	Bolhouse LLC	CAPACITORS, FILTER DRYER, CONNECTORS	375.00
199473	11/19/2024	2	008013	COMCAST	CABLE SERVICE	20.64
199474	11/19/2024	2	001660	CONSUMERS ENERGY	GAS EXPENSE MAINT GARAGE GAS/ELEC EXP BOARD OFFICE GAS/ELEC EXP BUS GARAGE ELECTRICITY ALL BUILDINGS	20.00+ 420.78+ 533.46+ 12,891.54+
Check Total						13,865.78=
199475	11/19/2024	2	002520	THE EXPONENT	500-4 PART FACILITY REQUEST FORMS	178.00
199476	11/19/2024	2	000207	FLEET PRIDE	PARTS PARTS	88.30+ 43.47+

Check #	Date	Run	Vendor	Name	Invoice Description	Amount
199477	11/19/2024	2	001030	GEM, INC.	GLYCOL PUMP CONTROL ISSUES	131.77=
					HS BOILER CONTROLS	705.00+
					REPLACE TXV ON VUV12	905.00+
					VAV NOT HEATING IN CLASSROOM A	1,765.04+
						2,165.00+
199478	11/19/2024	2	003280	IRONFREE & SOFTWATER	WATER COOLERS	5,540.04=
199479	11/19/2024	2	000977	JAMF SOFTWARE, LLC	EDU-ENH	136.00
199480	11/19/2024	2	011697	JOHNSON CONTROLS FIRE PROTECTION	ELEM MULTI PURPOSE	4,500.00
199481	11/19/2024	2	008344	KALAMAZOO SANITARY SUPPLY, LLC	CUSTODIAL SUPPLIES	1,359.18
					CUSTODIAL SUPPLIES	1,371.05+
					CUSTODIAL SUPPLIES	1,902.63+
199482	11/19/2024	2	001576	KNOWBE4, INC.	QUOTE Q-1226262	3,273.68=
199483	11/19/2024	2	003860	L.I.S.D	FINGER PRINTS ERHART/GRIFFITH	735.00
199484	11/19/2024	2	003800	LENAWEE COUNTY TREASURER	TAX REFUNDS	120.00
199485	11/19/2024	2	001151	LYONS LP GAS CO. INC	FUEL	1,619.37
199486	11/19/2024	2	007615	BRAD MASKA	REFUELED MARKED VAN	645.48
199487	11/19/2024	2	009785	MEREDITH FRANCIS, CPA, P.C.	FINAL FEES FINANCIAL STATEMENT AUDIT	36.35
199488	11/19/2024	2	004615	MODEL COVERALL SERVICE	UNIFORM SERVICE TRANSP/MAINT	10,800.00
					UNIFORM SERVICE TRANSP/MAINT	141.81+
						43.68+
199489	11/19/2024	2	001347	PRETTYMAN, VICKY	REIMBURSEMENT FOR BASIC FOODS & NUTR..	185.49=
199490	11/19/2024	2	010383	QUADIANT FINANCE USA, INC.	NEOSHIP SUBSCRIPTION	149.60
199491	11/19/2024	2	002240	SCHINDLER ELEVATOR CORPORATION	SERVICE CALL	15.00
199492	11/19/2024	2	007578	SCHOOL EQUITY CAUCUS	K-12 MEMBERSHIP DUES	1,400.03
199493	11/19/2024	2	000666	SCHOOL SPECIALTY, LLC	SUPPLIES/JODIE SHERMAN	900.00
					SUPPLIES/BRANDON ARNOLD	19.42+
					SUPPLIES/JODIE SHERMAN	91.34+
					SUPPLIES/JODIE SHERMAN	40.24+
					SUPPLIES/JODIE SHERMAN	10.20+
199494	11/19/2024	2	000720	STATE OF MICHIGAN	BOILER#MIR420567/MIR420570/MIR446436	161.20=
199495	11/19/2024	2	006240	THRUN LAW FIRM PC	WEBINAR	225.00
						150.00

Check #	Date	Run	Vendor	Name	Invoice Description	Amount
199496	11/19/2024	2	000898	T-MOBILE	CELL PHONE	31.43
199497	11/19/2024	2	001212	TRANSFINDER	ANNUAL TECHNICAL SUPPORT & UPGRADE PARTS	6,600.00
199498	11/19/2024	2	003784	TRANSPORTATION ACCESSORIES CO.		429.92
199499	11/19/2024	2	000687	COLLEGE BOARD	PSAT/MSQT:FALL 10, 11 GRADE	190.86
199500	11/22/2024	2	000793	DEPARTMENT OF TREASURY	BALANCE DUE 8038-T 2019	2,360.70
199502	11/01/2024	99	002941	GORDON FOOD SERVICE	FOOD AND SUPPLIES	4,419.78+
					FOOD AND SUPPLIES	2,699.29+
					FOOD AND SUPPLIES	2,090.97+
Check Total						9,210.04=
199503	11/08/2024	99	002941	GORDON FOOD SERVICE	FOOD AND SUPPLIES	1,948.89+
					FOOD AND SUPPLIES	3,044.62+
					FOOD AND SUPPLIES	4,633.52+
Check Total						9,627.03=
199504	11/12/2024	99	002941	GORDON FOOD SERVICE	FOOD AND SUPPLIES	105.85
199505	11/15/2024	99	002941	GORDON FOOD SERVICE	FOOD AND SUPPLIES	4,822.38+
					FOOD AND SUPPLIES	2,447.59+
					FOOD AND SUPPLIES	1,396.14+
Check Total						8,666.11=
199506	11/22/2024	99	002941	GORDON FOOD SERVICE	FOOD AND SUPPLIES	1,496.02+
					FOOD AND SUPPLIES	4,039.74+
					FOOD AND SUPPLIES	2,255.33+
Check Total						7,791.09=
199507	11/22/2024	800	002296	BLACKROCK COLLEGE ADVANTAGE 529	2024/2025 / 11 COL529 - PUTNAM 529 COLLEG..	200.00
199508	11/22/2024	800	003872	LENAWEE CARES	2024/2025 / 11 UNWAY - UNITED WAY	137.00
199509	11/22/2024	800	008565	TRUSTMARK VOLUNTARY BENEFIT SOL	2024/2025 / 11 BEN-LIFE - BENEFITS FOR LIFE ..	290.49
199510	11/26/2024	2	009720	CANADA DRY	ALA CARTE	202.59
199511	11/26/2024	2	001563	THE AMERICAN BOTTLING COMPANY	ALA CARTE	222.65
199512	11/26/2024	2	000713	PRAIRIE FARMS DAIRY	MILK	280.42+
					MILK	186.32+
					MILK	202.34+
					MILK	541.38+
					MILK	137.12+



Check #	Date	Run	Vendor	Name	Invoice Description	Amount
					MILK	153.37+
					MILK	659.20+
					MILK	119.85+
					MILK	170.63+
					MILK	339.24+
					MILK	51.80+
					MILK	34.53+
Check Total						2,876.20=
199513	11/26/2024	2	009233	ADRIAN SUPER LAUNDROMAT	GSRP	111.00+
					GSRP	126.00+
					GSRP	130.50+
					GSRP	132.00+
					GSRP	123.00+
					GSRP	156.00+
					GSRP	117.00+
					GSRP	139.50+
					GSRP	109.50+
Check Total						1,144.50=
199514	11/26/2024	2	000210	ADRIAN MECHANICAL SERVICES CO.	ATHLETIC END OF BUILDING NO HOT WATER	178.00+
					CSD-1 TESTING	3,551.24+
Check Total						3,729.24=
199515	11/26/2024	2	009269	BLUE CROSS BLUE SHIELD OF MICH-MC 601i	COVERAGE 12-01-24-12-31-24	898.60
199516	11/26/2024	2	001455	COMMUNICATIONS SERVICES LLC	1 BD5021 RADIO	311.45
199517	11/26/2024	2	001580	EQUESTRIAN OUTREACH PROGRAM	DONATION	100.00
199518	11/26/2024	2	001575	FARLEY, JESSE	MITTEN COOKIES/ICING	120.00
199519	11/26/2024	2	011301	HOLLAND BUS COMPANY	PARTS	202.08+
					PARTS	83.78+
Check Total						285.86=
199520	11/26/2024	2	004930	BRENDA HUBBARD	ROBOTICS/PETTY CASH	20.00
199521	11/26/2024	2	003385	HUBBARDS AUTO CENTER	VAN1 REPAIRS	55.26
199522	11/26/2024	2	003187	TERI HUNT	CLASSROOM SUPPLIES	25.00
199523	11/26/2024	2	003280	IRONFREE & SOFTWARE	WATER COOLERS	192.00
199524	11/26/2024	2	003860	L.I.S.D	STUBNITZ ENV. 5TH GRD FIELD TRIP	267.00

Check #	Date	Run	Vendor	Name	Invoice Description	Amount
199525	11/26/2024	2	001151	LYONS LP GAS CO. INC	FUEL	626.37+
					FUEL	651.98+
Check Total						1,278.35=
199526	11/26/2024	2	004615	MODEL COVERALL SERVICE	UNIFORM SERVICE TRANSP/MAINT	43.68+
					UNIFORM SERVICE TRANSP/MAINT	43.68+
Check Total						87.36=
199527	11/26/2024	2	000944	RED LETTER	DATA DROP CAT6	300.00
199528	11/26/2024	2	000666	SCHOOL SPECIALTY, LLC	OFFICE SUPPLIES	240.50
199529	11/26/2024	2	001339	STRESS FREE DOTS, LLC	2 URINE DRUG TESTING/1 BREATH ALCOHOL ..	165.00
199530	11/26/2024	2	000880	TC'S HARDWARE	MAINT/GRNDS/TRANSP SUPPLIES	337.80
199531	11/26/2024	2	000797	UNITY SCHOOL BUS PARTS	PARTS	53.75
199532	11/26/2024	2	008301	BAXTER GREEN ENTERPRISES, LLC	IRRIGATION WINTERIZATION	390.00
199533	11/26/2024	2	011067	SCHOLASTIC BOOK FAIRS - 04	FALL BOOK FAIR - ELEMENTARY	7,813.67
Total of All Checks						126,672.25
Less Voids						0.00
Grand Total						126,672.25

Check Summary

Check Status	Count	Amount
Open	75	126,672.25
Cleared	0	0.00
Void	0	0.00
Total	75	126,672.25



Check Register

Onsted Community Schools

Bank Account BANK-MI-ATHL, From 11/01/2024 to 11/30/2024

Check #	Date	Run	Vendor	Name	Invoice Description	Amount
122902	11/04/2024	101	011118	BRUCE BRITTON	OFFICIAL - MS BASKETBALL 11/6	100.00
122903	11/04/2024	101	000986	LON SMITH	OFFICIAL - MS BASKETBALL 11/6	100.00
122904	11/05/2024	101	001574	HUTCHISON, RANDY	SOFTBALL ITEMS	400.11
122905	11/05/2024	101	011121	DEVILS LAKE GC	GIRLS' GOLF FEES	1,202.00
122906	11/05/2024	101	001205	GAME ONE	GIRLS' BKB APPAREL	131.46
122907	11/05/2024	101	001425	KEENOY, MARJORIE	ATHLETIC TRAINER	409.50
122908	11/05/2024	101	001417	SIMPSON, KAYLIE	ATHLETIC TRAINER	1,189.50
122909	11/05/2024	101	004991	THE NEFF COMPANY	RECOGNITION GYM BANNERS	394.19
122910	11/08/2024	101	001567	VICTORY CUSTOM CO.	MS BKB WARMUP SHIRTS	520.00
122911	11/08/2024	101	007615	BRAD MASKA	TEAM BONDING	156.00
122912	11/11/2024	101	011118	BRUCE BRITTON	OFFICIAL - MS BKB 11/13	100.00
122913	11/11/2024	101	000170	GLENN NEWLIN	OFFICIAL - MS BKB 11/13	100.00
122914	11/11/2024	101	011514	TAYLOR HUTCHINSON	YOUTH CAMP JERSEYS	1,128.00
122915	11/11/2024	101	004991	THE NEFF COMPANY	ALL STATE AWARD PLAQUES	480.48
122916	11/11/2024	101	003386	HUDSON AREA SCHOOLS	LENAWEE FOOTBALL COACHES NIGHT	130.00
122917	11/12/2024	101	001368	MIAAA	MIAAA Conference Registration	225.00
122918	11/13/2024	101	001205	GAME ONE	GIRLS BASKETBALL APPAREL	826.56
122919	11/13/2024	101	000563	IMAGECRAFT	AWARD PLAQUES GOLF/VOLLEYBALL	62.00
122920	11/14/2024	101	001425	KEENOY, MARJORIE	ATHLETIC TRAINER	260.00
122921	11/15/2024	101	000410	CCCAM TREASURER	ENTRY FEE CCCAM SCHOLARSHIP INVITATIO..	225.00
122922	11/15/2024	101	000410	CCCAM TREASURER	MEMBERSHIP - CCCAM (GOETZ)	40.00
122923	11/15/2024	101	000420	MATBOSS, LLC	WRESTLING VIDEO STATS	499.00
122924	11/15/2024	101	007694	VICTORY CUSTOM APPAREL	TEAM APPAREL	1,382.00
122925	11/18/2024	101	010468	B GOMOLUCH ASSIGNING LLC	WINTER (BASKETBALL) OFFICIAL ASSIGNING	880.00
122926	11/18/2024	101	010248	ONSTED ATHLETIC DEPARTMENT	CASH FOR SCRIMMAGE OFFICIAL 11/19	240.00
122927	11/18/2024	101	000563	IMAGECRAFT	FOOTBALL PLAQUES	130.00
122928	11/19/2024	101	001234	GARY SULLIVAN	OFFICIAL - MS BASKETBALL 11/20	100.00
122929	11/19/2024	101	001010	JOE TERWILLIGER	OFFICIAL - MS BASKETBALL 11/20	100.00
122930	11/19/2024	101	001417	SIMPSON, KAYLIE	ATHLETIC TRAINER	390.00
122931	11/21/2024	101	001567	VICTORY CUSTOM CO.	HS BOYS BASKETBALL APPAREL	639.00
122932	11/25/2024	101	000315	CHAD BANGERTER	OFFICIAL - JV BOYS' BASKETBALL 11/26	80.00
122933	11/25/2024	101	011360	JAMES KRZYZANIAK	OFFICIAL - MS BASKETBALL 11/25	100.00
122934	11/25/2024	101	001256	MARK BEOUGHER	OFFICIAL - MS BASKETBALL 11/25	100.00
122935	11/25/2024	101	001093	MICHAEL JORDON	OFFICIAL - JV BOYS' BASKETBALL 11/26	80.00
122936	11/25/2024	101	009394	NICHOLAS MARSHALL	OFFICIAL - VARSITY BOYS' BASKETBALL 11/26	95.00
122937	11/25/2024	101	009766	PETE AMBS	OFFICIAL - VARSITY BOYS' BASKETBALL 11/26	95.00
122938	11/25/2024	101	001204	TJ OLSEN PHOTOGRAPHY	BOYS' BASKETBALL WALL POSTERS	360.00

Check #	Date	Run	Vendor	Name	Invoice Description	Amount
122939	11/25/2024	101	001261	PHILIP WALESBY	OFFICIAL - VARSITY BOYS' BASKETBALL 11/26	95.00
122940	11/25/2024	101	001261	PHILIP WALESBY	OFFICIAL - VARSITY BOYS' BASKETBALL 11/26	95.00
122941	11/25/2024	101	001417	SIMPSON, KAYLIE	ATHLETIC TRAINER	1,189.50
122942	11/26/2024	101	007615	BRAD MASKA	BKB SCOREBOARD	127.08
122943	11/26/2024	101	001570	GUTSY ATHLETIC	BASEBALL UNIFORMS	2,554.86
122944	11/26/2024	101	000880	TC'S HARDWARE	POWERLIFTING AND WEIGHT ROOM KEYS	25.32
122945	11/27/2024	101	001006	RACHEL STEHLIK	CHEER CLINICS	1,500.00
Total of All Checks						19,036.56
Less Voids						1,284.50
Grand Total						17,752.06

Check Summary

Check Status	Count	Amount
Open	42	17,752.06
Cleared	0	0.00
Void	2	1,284.50
Total	44	19,036.56

Electronic Banking Transactions Not Included in Check Disbursements				
Date	Payee	Amount	Description	Monthly Total
11/8/2024	Premier Bank	260,398.35	Pay 10-Direct Deposit/Net Pay	
11/8/2024	TSA	10,418.35	Pay 10-403/457 Deductions	
11/8/2024	US Treasury	78,468.69	Pay 10-Payroll Taxes	
11/8/2024	MPSERS	143,302.46	Pay 10-Retirement	
11/8/2024	Health Equity	2,276.30	Pay 10-HSA additional Equity	
11/22/2024	Premier Bank	250,658.59	Pay 11-Direct Deposit/Net Pay	
11/22/2024	TSA	10,418.35	Pay 11-403/457 Deductions	
11/22/2024	US Treasury	77,169.79	Pay 11-Payroll Taxes	
11/22/2024	MPSERS	141,743.39	Pay 11-Retirement	
11/22/2024	Health Equity	2,276.30	Pay 11-HSA additional Equity	
11/30/2024	State of MI taxes	25,349.97		
11/4/2024	PCARD	33,683.86	Credit Card purchases 9/28/24-10/27/24	
NOVEMBER Monthly Total				\$ 1,036,164.40



Statement

Account Name:	ONSTED CS ONE CARDS	Card Number:	xxxx-xxxx-xxxx-5903
Company Name:	ONSTED COMMUNITY SCHOOLS	Account Limit:	\$ 100,000.00
Employee ID:	BILLINGACCT5903	Available Credit:	\$ 86,651.90
Statement Date (MM/DD/YYYY):	11/27/2024	Currency:	U.S. DOLLAR
Payment Due Date (MM/DD/YYYY):	12/24/2024		

Statement Summary:

Report any items which do not agree with your records within 30 days of the statement date.

Previous Balance:	\$ 14,292.08
Payments:	\$ -14,292.08
Adjustments:	\$ 0.00
Net Purchases:	\$ 13,348.10
Cash Advance:	\$ 0.00
Fees:	\$ 0.00
Other Charges:	\$ 0.00
New Account Balance:	\$ 13,348.10

Transaction Summary:

Trans Date	Posting Date Trans ID	Description	Pre-Tax Amount Auth #	Total Tax	Trans Amount
Card Number xxxx-xxxx-xxxx-5903 ONSTED CS ONE CARDS					
11/04	11/04 559148560	AUTOMATIC PYMT RECEIVED	\$ -14,292.08	\$ 0.00	\$ -14,292.08
			TOTAL CREDITS xxxx-xxxx-xxxx-5903		\$ -14,292.08
			TOTAL DEBITS xxxx-xxxx-xxxx-5903		\$ 0.00
Card Number xxxx-xxxx-xxxx-3149 BIRINGER, DYAN					
10/29	10/30 558629545	COUNTRY MARKET #11 ADRIAN MI	\$ 13.10 021498	\$ 0.00	\$ 13.10
10/30	10/31 558911301	PAYPAL MATHDRAWING 4029357733 CA	\$ 1,475.00 045889	\$ 0.00	\$ 1,475.00
11/07	11/08 560246397	VOYAGER SOPRIS LEARNG 800-547-6747 TX	\$ 2,557.40 009348	\$ 0.00	\$ 2,557.40
11/08	11/11 560559292	AMAZON MKTPL W685N7VN3 AMZN.COM/BILL WA	\$ 78.67 090984	\$ 0.00	\$ 78.67
			TOTAL CREDITS xxxx-xxxx-xxxx-3149		\$ 0.00
			TOTAL DEBITS xxxx-xxxx-xxxx-3149		\$ 4,124.17
Card Number xxxx-xxxx-xxxx-5735 DAVIS, MARSHA					
10/26	10/28 558185279	AMAZON RETA P84025GP3 SEATTLE WA	\$ 30.57 099637	\$ 0.00	\$ 30.57
10/28	10/29 558434768	AMAZON MARK 5R9YC8WQ3 SEATTLE WA	\$ 49.79 067525	\$ 0.00	\$ 49.79

10/28	10/29 558434767	AMAZON MKTPL ES8T21ES3 AMZN.COM/BILL WA	\$ 19.99 035835	\$ 0.00	
10/29	10/30 558629542	AMAZON MARK Z297P0GP3 SEATTLE WA	\$ 76.52 047041	\$ 0.00	\$ 76.52
10/29	10/30 558629468	AMZN MKTP US K15IQ7643 AMZN.COM/BILL WA	\$ 87.96 099619	\$ 0.00	\$ 87.96
10/30	10/31 558911223	AMAZON RETA K31057QN3 SEATTLE WA	\$ 84.96 041044	\$ 0.00	\$ 84.96
10/31	11/01 559135617	TEACHERSPAYTEACHERS.CO 6465880910 CA	\$ 28.00 068691	\$ 0.00	\$ 28.00
11/03	11/04 559259567	AMAZON MARK 6E5HG9F83 SEATTLE WA	\$ 19.99 037195	\$ 0.00	\$ 19.99
11/04	11/05 559623534	EB VIRTUAL PRODUCT TR 8014137200 CA	\$ 120.00 012622	\$ 0.00	\$ 120.00
11/04	11/05 559623606	AMAZON MARK HW6I432D3 SEATTLE WA	\$ 56.97 028365	\$ 0.00	\$ 56.97
11/05	11/06 559812888	AUDIBLE RF4U38B63 AMZN.COM/BILL NJ	\$ 14.95 015445	\$ 0.00	\$ 14.95
11/05	11/06 559812889	AUDIBLE AMZN.COM/BILL NJ	\$ -14.95 096509	\$ 0.00	\$ -14.95
11/06	11/06 559812890	JONES & BARTLETT LEARN 8008320034 MA	\$ 80.66 009125	\$ 0.00	\$ 80.66
11/07	11/08 560246319	EB MORPHEME MAGIC BOO 8014137200 CA	\$ 120.00 024033	\$ 0.00	\$ 120.00
11/07	11/08 560246320	AMAZON MARK H079I6KL3 SEATTLE WA	\$ 9.89 051805	\$ 0.00	\$ 9.89
11/09	11/11 560559134	AMAZON MARK KB4X113Q3 SEATTLE WA	\$ 37.46 011672	\$ 0.00	\$ 37.46
11/10	11/11 560559133	WAL-MART #1836 ADRIAN MI	\$ 150.61 076272	\$ 9.04	\$ 159.65
11/10	11/11 560559212	AMAZON RETA LK97O6IX3 SEATTLE WA	\$ 29.99 013902	\$ 0.00	\$ 29.99
11/10	11/11 560559135	AMAZON RETA C669528X3 SEATTLE WA	\$ 45.40 072082	\$ 0.00	\$ 45.40
11/10	11/11 560559211	AMAZON RETA 6326Y1G03 SEATTLE WA	\$ 67.80 067994	\$ 0.00	\$ 67.80
11/16	11/18 561587991	AMAZON MKTPL BR6CM43P3 AMZN.COM/BILL WA	\$ 29.99 098280	\$ 0.00	\$ 29.99
11/19	11/19 561915823	AMAZON MKTPL X85O42DG3 AMZN.COM/BILL WA	\$ 9.98 024443	\$ 0.00	\$ 9.98
11/21	11/22 562602499	AMAZON MARK OZ3EC9GG3 SEATTLE WA	\$ 15.99 088513	\$ 0.00	\$ 15.99
11/23	11/25 562812986	AMAZON MARK Q49497DC3 SEATTLE WA	\$ 103.31 024142	\$ 0.00	\$ 103.31
11/25	11/26 563134795	AMZN MKTP US AZ37C8ZI3 AMZN.COM/BILL WA	\$ 19.48 056712	\$ 0.00	\$ 19.48
11/25	11/26 563134796	AMZN MKTP US IM5QP29Z3 AMZN.COM/BILL WA	\$ 17.48 003750	\$ 0.00	\$ 17.48
11/25	11/26 563134794	AMZN MKTP US KE51W6N63 AMZN.COM/BILL WA	\$ 17.99 000957	\$ 0.00	\$ 17.99

11/26	11/27 563291094	AMAZON MARK Z36WB2A00 SEATTLE WA	\$ 977.46 084871	\$ 0.00	
11/26	11/27 563291093	AMAZON MARK Z367H2T90 SEATTLE WA	\$ 181.90 085245	\$ 0.00	\$ 181.90
11/27	11/27 563291095	AMAZON MARK 347439VN3 SEATTLE WA	\$ 9.98 030214	\$ 0.00	\$ 9.98

TOTAL CREDITS xxxx-xxxx-xxxx-5735 **\$ -14.95**
TOTAL DEBITS xxxx-xxxx-xxxx-5735 **\$ 2,524.11**

Card Number xxxx-xxxx-xxxx-2955 ELLISON, ALAINA

10/28	10/29 558434766	AMAZON MKTPL 236E56O43 AMZN.COM/BILL WA	\$ 2.99 090730	\$ 0.00	\$ 2.99
10/29	10/30 558629464	AMAZON MKTPL 6R7EU5VK3 AMZN.COM/BILL WA	\$ 455.62 002041	\$ 0.00	\$ 455.62
10/29	10/30 558629465	AMAZON MKTPL KT5YN1Z43 AMZN.COM/BILL WA	\$ 59.43 033715	\$ 0.00	\$ 59.43
11/08	11/08 560246317	SP JORDYNS SUMMER SH CUMMING GA	\$ 205.28 094056	\$ 0.00	\$ 205.28
11/09	11/11 560559051	CRYSTAL MOUNTAIN RESOR THOMPSONVILLE MI	\$ 44.43 003668	\$ 0.00	\$ 44.43
11/10	11/11 560558974	MEIJER # 045 ADRIAN MI	\$ 341.65 053252	\$ 20.49	\$ 362.14
11/10	11/11 560559050	EXXON MOUNTAIN VIEW MI THOMPSONVILLE MI	\$ 46.30 034878	\$ 0.00	\$ 46.30
11/11	11/12 560774339	WESCO #11 BROOKLYN MI	\$ 76.80 031929	\$ 0.00	\$ 76.80
11/13	11/14 561081733	HARVARD ED PUBLISHING CAMBRIDGE MA	\$ 32.00 038833	\$ 0.00	\$ 32.00
11/21	11/22 562602424	CORPORATE CASUALS - 2 CONCORD MA	\$ 1,599.99 061410	\$ 100.01	\$ 1,700.00

TOTAL CREDITS xxxx-xxxx-xxxx-2955 **\$ 0.00**
TOTAL DEBITS xxxx-xxxx-xxxx-2955 **\$ 2,984.99**

Card Number xxxx-xxxx-xxxx-5672 ROYCE, JONATHAN

10/24	10/28 558185280	FNTZF - LDG - HYATT PL FLINT MI	\$ 157.62 066718	\$ 0.00	\$ 157.62
10/29	10/30 558629543	MICHASSOCSA 5173275910 MI	\$ 550.00 011220	\$ 0.00	\$ 550.00
11/21	11/22 562602501	JIMMY JOHNS - 2781 FLINT MI	\$ 15.96 033823	\$ 0.00	\$ 15.96
11/21	11/25 562812987	FNTZF - LDG - HYATT PL FLINT MI	\$ 173.16 035561	\$ 0.00	\$ 173.16
11/25	11/27 563291096	MSBO 5173272584 MI	\$ 150.00 031735	\$ 0.00	\$ 150.00

TOTAL CREDITS xxxx-xxxx-xxxx-5672 **\$ 0.00**
TOTAL DEBITS xxxx-xxxx-xxxx-5672 **\$ 1,046.74**

Card Number xxxx-xxxx-xxxx-6109 STRONG, ANITA

10/25	10/28 558185354	AMAZON MARK PB65N5PH3 SEATTLE WA	\$ 361.07 047475	\$ 0.00	
10/25	10/28 558185353	AMZN MKTP US OA6Z741N3 AMZN.COM/BILL WA	\$ 117.51 090759	\$ 0.00	\$ 117.51
10/26	10/28 558185355	AMAZON MARK 799801ZX3 SEATTLE WA	\$ 143.96 084892	\$ 0.00	\$ 143.96
10/30	10/31 558911300	AMZN MKTP US K15TN1EG3 AMZN.COM/BILL WA	\$ 629.00 047166	\$ 0.00	\$ 629.00
11/05	11/06 559812967	AMAZON MARK 5R91Z6CM3 SEATTLE WA	\$ 122.90 014961	\$ 0.00	\$ 122.90
11/06	11/07 559953931	AMAZON MARK DM8591RA3 SEATTLE WA	\$ 651.99 013507	\$ 0.00	\$ 651.99
11/13	11/13 561011797	AMAZON RETA CK44J5E63 SEATTLE WA	\$ 6.58 084962	\$ 0.00	\$ 6.58
11/22	11/25 562812989	AMZN MKTP US 0908P40U3 AMZN.COM/BILL WA	\$ 147.99 077113	\$ 0.00	\$ 147.99
11/23	11/25 562813295	AMAZON MARK NX37M7D23 SEATTLE WA	\$ 13.43 004439	\$ 0.00	\$ 13.43
11/24	11/25 562813296	AMAZON RETA J32WJ2IU3 SEATTLE WA	\$ 162.50 087208	\$ 0.00	\$ 162.50
11/25	11/26 563134797	AMAZON MARK LO0WC0QD3 SEATTLE WA	\$ 326.11 065612	\$ 0.00	\$ 326.11

TOTAL CREDITS xxxx-xxxx-xxxx-6109 **\$ 0.00**
TOTAL DEBITS xxxx-xxxx-xxxx-6109 **\$ 2,683.04**



Statement

Account Name:	ONSTED CS DEPT CARDS	Card Number:	xxxx-xxxx-xxxx-5911
Company Name:	ONSTED COMMUNITY SCHOOLS	Account Limit:	\$ 100,000.00
Employee ID:	BILLINGACCT5911	Available Credit:	\$ 79,664.24
Statement Date (MM/DD/YYYY):	11/27/2024	Currency:	U.S. DOLLAR
Payment Due Date (MM/DD/YYYY):	12/24/2024		

Statement Summary:

Report any items which do not agree with your records within 30 days of the statement date.

Previous Balance:	\$ 22,721.74
Payments:	\$ -22,721.74
Adjustments:	\$ 0.00
Net Purchases:	\$ 20,335.76
Cash Advance:	\$ 0.00
Fees:	\$ 0.00
Other Charges:	\$ 0.00
New Account Balance:	\$ 20,335.76

Transaction Summary:

Trans Date	Posting Date Trans ID	Description	Pre-Tax Amount Auth #	Total Tax	Trans Amount
Card Number xxxx-xxxx-xxxx-5911 ONSTED CS DEPT CARDS					
11/04	11/04 559148561	AUTOMATIC PYMT RECEIVED	\$ -22,721.74	\$ 0.00	\$ -22,721.74
			TOTAL CREDITS xxxx-xxxx-xxxx-5911		\$ -22,721.74
			TOTAL DEBITS xxxx-xxxx-xxxx-5911		\$ 0.00
Card Number xxxx-xxxx-xxxx-5659 BUILDING, ELEMENTARY SCHOOL					
11/01	11/04 559259568	TIM HORTONS #919360 ADRIAN MI	\$ 47.89 045767	\$ 2.87	\$ 50.76
11/06	11/07 559953854	DOLLAR GENERAL #30229 ONSTED MI	\$ 49.20 019717	\$ 0.92	\$ 50.12
11/08	11/11 560559213	PAR KELLYS DOWNTOWN LANSING MI	\$ 15.13 075632	\$ 0.00	\$ 15.13
11/08	11/11 560559291	BOBCAT BONNIE S LANSIN LANSING MI	\$ 18.25 017123	\$ 0.00	\$ 18.25
11/10	11/11 560559290	DOUBLETREE HOTELS LANSING MI	\$ 437.31 076594	\$ 0.00	\$ 437.31
11/10	11/11 560559214	CAPITAL CITY GRILL F A LANSING MI	\$ 20.90 014375	\$ 0.00	\$ 20.90
11/10	11/11 560559215	DOUBLETREE HOTELS LANSING MI	\$ 35.00 042389	\$ 0.00	\$ 35.00
11/11	11/12 560773166	TEACHERSPAYTEACHERS.CO 6465880910 CA	\$ 3.25 024595	\$ 0.00	\$ 3.25

11/12	11/12 560773167	EZCATER SUBWAY 8004881803 MA	\$ 507.04 093504	\$ 30.42	
11/13	11/14 561081805	AMAZON RETA 146QR4G93 SEATTLE WA	\$ 31.96 050593	\$ 0.00	\$ 31.96
11/20	11/20 562086039	TEACHERSPAYTEACHERS.CO 6465880910 CA	\$ 6.75 021841	\$ 0.00	\$ 6.75
11/21	11/22 562602500	TEACHERSPAYTEACHERS.CO 6465880910 CA	\$ 3.99 054335	\$ 0.00	\$ 3.99

TOTAL CREDITS xxxx-xxxx-xxxx-5659 **\$ 0.00**
TOTAL DEBITS xxxx-xxxx-xxxx-5659 **\$ 1,210.88**

Card Number xxxx-xxxx-xxxx-9690 BUILDING, HIGH SCHOOL

10/25	10/28 558185278	AMAZON MARK HZ61N67D3 SEATTLE WA	\$ 165.94 056406	\$ 0.00	\$ 165.94
10/26	10/28 558185276	SAMS CLUB #6658 JACKSON MI	\$ 4.28 083777	\$ 0.00	\$ 4.28
10/26	10/28 558185201	SAMS CLUB #6658 JACKSON MI	\$ 240.52 038585	\$ 0.00	\$ 240.52
10/26	10/28 558185277	AMAZON MKTPL P66AN82P3 AMZN.COM/BILL WA	\$ 113.92 058486	\$ 0.00	\$ 113.92
10/29	10/30 558629467	AMAZON MARK TR2019Q03 SEATTLE WA	\$ 442.07 050025	\$ 0.00	\$ 442.07
10/30	10/30 558629466	AMAZON MKTPL BD34E8TD3 AMZN.COM/BILL WA	\$ 65.63 044389	\$ 0.00	\$ 65.63
10/30	10/31 558911222	AMAZON MARK GH3QH0VP3 SEATTLE WA	\$ 35.77 007775	\$ 0.00	\$ 35.77
10/30	10/31 558911221	AMAZON MKTPL 8A5G584Q3 AMZN.COM/BILL WA	\$ 12.19 032682	\$ 0.00	\$ 12.19
10/31	11/04 559259566	NASSP PRODUCT & SERVIC RESTON VA	\$ 637.50 091942	\$ 38.25	\$ 675.75
11/01	11/04 559259565	SAMS CLUB RENEWAL YPSILANTI MI	\$ 110.00 063047	\$ 0.00	\$ 110.00
11/01	11/04 559259488	LITTLE CAESARS 3250-00 ADRIAN MI	\$ 75.14 027691	\$ 0.00	\$ 75.14
11/03	11/04 559259564	AMAZON MKTPL 7W5WA7C73 AMZN.COM/BILL WA	\$ 217.37 098382	\$ 0.00	\$ 217.37
11/04	11/05 559623533	AMAZON MKTPL VQ2RK38G3 AMZN.COM/BILL WA	\$ 32.62 029604	\$ 0.00	\$ 32.62
11/05	11/06 559812887	AMZN MKTP US 0J29Y02N3 AMZN.COM/BILL WA	\$ 76.98 092907	\$ 0.00	\$ 76.98
11/05	11/07 559953853	EXPLORICA INC 888-3107121 MA	\$ 510.00 090494	\$ 0.00	\$ 510.00
11/05	11/07 559953852	EXPLORICA INC 888-3107121 MA	\$ 510.00 010724	\$ 0.00	\$ 510.00
11/06	11/07 559953851	TEACHERSPAYTEACHERS.CO 6465880910 CA	\$ 7.30 018336	\$ 0.00	\$ 7.30
11/06	11/07 559953775	AMAZON MKTPL IR07G0NW3 AMZN.COM/BILL WA	\$ 59.53 915575	\$ 0.00	\$ 59.53
11/06	11/07 559953774	AMAZON MKTPL J574P7243 AMZN.COM/BILL WA	\$ 174.20 901089	\$ 0.00	\$ 174.20

11/06	11/08 560246318	NASSP PRODUCT & SERVI RESTON VA	\$ 56.49 021093	\$ 2.97	
11/08	11/11 560559054	PY BIGGIES PIZZA ADRIAN MI	\$ 56.00 059228	\$ 0.00	\$ 56.00
11/10	11/11 560559131	SAMS CLUB #6658 JACKSON MI	\$ 197.55 041267	\$ 0.00	\$ 197.55
11/11	11/11 560559132	TEACHERSPAYTEACHERS.CO 6465880910 CA	\$ 10.50 091269	\$ 0.00	\$ 10.50
11/11	11/12 560773165	AMAZON RETA HY7RN3XS3 SEATTLE WA	\$ 15.36 060922	\$ 0.00	\$ 15.36
11/13	11/14 561081734	AMAZON MKTPL TG2PP0663 AMZN.COM/BILL WA	\$ 24.99 037250	\$ 1.50	\$ 26.49
11/14	11/15 561374739	TEACHERSPAYTEACHERS.CO 6465880910 CA	\$ 8.75 065710	\$ 0.00	\$ 8.75
11/15	11/18 561587990	AMAZON MKTPL T30C50F53 AMZN.COM/BILL WA	\$ 36.78 064968	\$ 0.00	\$ 36.78
11/18	11/22 562602426	ROCKFORD 616-8660143 MI	\$ 85.55 053848	\$ 2.65	\$ 88.20
11/20	11/21 562376690	SAMSClub #6658 JACKSON MI	\$ 179.82 016023	\$ 0.00	\$ 179.82
11/20	11/21 562376689	MEIJER # 056 JACKSON MI	\$ 19.75 094168	\$ 1.18	\$ 20.93
11/20	11/21 562376764	TEACHERSPAYTEACHERS.CO 6465880910 CA	\$ 2.50 083515	\$ 0.00	\$ 2.50
11/21	11/22 562602425	KIWANIS INTERNATIONAL INDIANAPOLIS IN	\$ 391.00 029026	\$ 0.00	\$ 391.00
11/22	11/25 562813449	AMAZON MKTPL 4N4UU0BQ3 AMZN.COM/BILL WA	\$ 47.92 075109	\$ 0.00	\$ 47.92
11/22	11/25 562813447	MARCOS PIZZA 1076 BROOKLYN MI	\$ 43.59 003097	\$ 0.00	\$ 43.59
11/23	11/25 562812985	WAL-MART #1836 ADRIAN MI	\$ 47.32 073953	\$ 0.00	\$ 47.32
11/24	11/25 562813448	SAMS CLUB #6658 JACKSON MI	\$ 246.22 071243	\$ 0.00	\$ 246.22
11/24	11/25 562813450	MEIJER # 056 JACKSON MI	\$ 93.17 047076	\$ 1.47	\$ 94.64

TOTAL CREDITS xxxx-xxxx-xxxx-9690 \$ 0.00
TOTAL DEBITS xxxx-xxxx-xxxx-9690 \$ 5,102.24

Card Number xxxx-xxxx-xxxx-0554 BUILDING, MIDDLE SCHOOL

11/02	11/04 559259487	OPENAI CHATGPT SUBSCR SAN FRANCISCO CA	\$ 20.00 038009	\$ 0.00	\$ 20.00
11/08	11/11 560558973	AMZN MKTP US 4C9A04ZD3 AMZN.COM/BILL WA	\$ 66.26 039001	\$ 0.00	\$ 66.26
11/11	11/12 560774337	AMAZON.COM 2K7ZJ7W73 AMZN.COM/BILL WA	\$ 24.59 058210	\$ 0.00	\$ 24.59
11/11	11/12 560774338	SP GLOWFORGE STORE SEATTLE WA	\$ 493.32 053428	\$ 0.00	\$ 493.32
11/11	11/12 560774336	AMAZON.COM RD06O3NA3 AMZN.COM/BILL WA	\$ 92.46 023787	\$ 0.00	\$ 92.46

11/18	11/19 561915821	PAY YMCA STORER CAMPS SYLVANIA OH	\$ 306.00 032983	\$ 0.00	\$ 306.00
11/22	11/25 562813370	CORPORATE CASUALS - 2 CONCORD MA	\$ 1,701.48 026715	\$ 106.36	\$ 1,807.84
11/26	11/26 563134716	AMAZON MKTPL T00MK4XC3 AMZN.COM/BILL WA	\$ 28.87 027677	\$ 0.00	\$ 28.87

TOTAL CREDITS xxxx-xxxx-xxxx-0554 \$ 0.00
TOTAL DEBITS xxxx-xxxx-xxxx-0554 \$ 2,839.34

Card Number xxxx-xxxx-xxxx-7664 DEPARTMENT, ATHLETICS

10/27	10/28 558185427	ANET ATHLETE FEATURES SHERWOOD OR	\$ 9.99 080014	\$ 0.00	\$ 9.99
10/28	10/28 558185426	NFHSNETWORK 039C7B02DD CHAMBLEE GA	\$ 11.99 085680	\$ 0.00	\$ 11.99
11/04	11/05 559623607	AMAZON MKTPL 6M6BP4MU3 AMZN.COM/BILL WA	\$ 15.99 069482	\$ 0.00	\$ 15.99
11/05	11/05 559623608	AMZN MKTP US S22OC6OT3 AMZN.COM/BILL WA	\$ 189.88 014416	\$ 0.00	\$ 189.88
11/05	11/06 559812968	EPIC SPORTS BEL AIRE KS	\$ 398.69 077595	\$ 0.00	\$ 398.69
11/15	11/18 561587992	APPLE.COM/BILL 866-712-7753 CA	\$ 10.99 070722	\$ 0.00	\$ 10.99
11/19	11/20 562086041	AMAZON MKTPL UH0WN9AF3 AMZN.COM/BILL WA	\$ 45.98 072568	\$ 0.00	\$ 45.98
11/21	11/22 562602502	AMZN MKTP US HE2252I53 AMZN.COM/BILL WA	\$ 109.98 060817	\$ 0.00	\$ 109.98
11/21	11/22 562602503	AMAZON.COM GL5U74N13 AMZN.COM/BILL WA	\$ 183.00 090415	\$ 0.00	\$ 183.00
11/21	11/22 562602579	AMZN MKTP US 6O4211Q43 AMZN.COM/BILL WA	\$ 1,022.96 084582	\$ 0.00	\$ 1,022.96
11/22	11/22 562602581	AMAZON.COM R03AJ5FS3 AMZN.COM/BILL WA	\$ 647.97 013097	\$ 0.00	\$ 647.97
11/22	11/22 562602580	AMZN MKTP US O32BF0Q73 AMZN.COM/BILL WA	\$ 756.52 006097	\$ 0.00	\$ 756.52
11/22	11/22 562602582	AMZN MKTP US SS55B5VG3 AMZN.COM/BILL WA	\$ 469.87 062254	\$ 0.00	\$ 469.87
11/22	11/22 562602583	AMZN MKTP US F80P73DO3 AMZN.COM/BILL WA	\$ 164.99 024027	\$ 0.00	\$ 164.99
11/22	11/25 562813297	APPLE.COM/BILL 866-712-7753 CA	\$ 9.99 077432	\$ 0.00	\$ 9.99
11/26	11/27 563291172	ANET ATHLETE FEATURES SHERWOOD OR	\$ 9.99 097099	\$ 0.00	\$ 9.99

TOTAL CREDITS xxxx-xxxx-xxxx-7664 \$ 0.00
TOTAL DEBITS xxxx-xxxx-xxxx-7664 \$ 4,058.78

Card Number xxxx-xxxx-xxxx-0618 DEPARTMENT, CUSTODIAL

10/28	10/29 558434769	THE WEBSTAIRANT STORE LANCASTER PA	\$ 444.09 080180	\$ 0.00	\$ 444.09
10/30	10/31 558911299	ZORO TOOLS INC BUFFALO GROVE IL	\$ 42.06 077540	\$ 0.00	\$ 42.06

11/06	11/07 559953855	ZORO TOOLS INC BUFFALO GROVE IL	\$ 162.53 063916	\$ 0.00	\$ 162.53
11/07	11/08 560246396	AMAZON MARK 6K5848973 SEATTLE WA	\$ 48.02 041049	\$ 0.00	\$ 48.02
11/12	11/14 561081806	THE WEBSTaurant STORE LANCASTER PA	\$ 561.71 034166	\$ 0.00	\$ 561.71
11/20	11/21 562376765	ZORO TOOLS INC BUFFALO GROVE IL	\$ 112.58 013776	\$ 0.00	\$ 112.58
			TOTAL CREDITS xxxx-xxxx-xxxx-0618		\$ 0.00
			TOTAL DEBITS xxxx-xxxx-xxxx-0618		\$ 1,370.99

Card Number xxxx-xxxx-xxxx-4829 DEPARTMENT, MAINTENANCE

11/08	11/11 560559052	AMZN MKTP US 8B46Y77T3 AMZN.COM/BILL WA	\$ 94.55 005811	\$ 0.00	\$ 94.55
11/08	11/11 560559053	SUPPLYHOUSE.COM 888-757-4774 NY	\$ 94.79 029123	\$ 0.00	\$ 94.79
11/11	11/13 561011795	HOMEDEPOT.COM 800-430-3376 GA	\$ 244.86 088389	\$ 0.00	\$ 244.86
11/12	11/13 561011794	BERLS COMMERCIAL SUPP 7049372673 NC	\$ 68.66 095531	\$ 0.00	\$ 68.66
11/14	11/15 561374738	THE WEBSTaurant STORE LANCASTER PA	\$ 184.87 003795	\$ 0.00	\$ 184.87
11/16	11/18 561587917	THE WEBSTaurant STORE LANCASTER PA	\$ 419.99 062690	\$ 0.00	\$ 419.99
11/18	11/19 561915822	THE WEBSTaurant STORE LANCASTER PA	\$ 112.33 017570	\$ 0.00	\$ 112.33
11/19	11/20 562086038	AMAZON RETA RE0LR1FF3 SEATTLE WA	\$ 247.48 077247	\$ 0.00	\$ 247.48
11/22	11/25 562813373	SUPPLYHOUSE.COM 888-757-4774 NY	\$ 386.78 097594	\$ 0.00	\$ 386.78
11/22	11/25 562813446	PGH WATER 4124877105 PA	\$ 168.30 098286	\$ 0.00	\$ 168.30
11/22	11/25 562813372	THE WEBSTaurant STORE LANCASTER PA	\$ 585.05 032766	\$ 0.00	\$ 585.05
11/24	11/25 562813374	AMAZON MKTPL HR4DH3IX3 AMZN.COM/BILL WA	\$ 27.98 003506	\$ 0.00	\$ 27.98
			TOTAL CREDITS xxxx-xxxx-xxxx-4829		\$ 0.00
			TOTAL DEBITS xxxx-xxxx-xxxx-4829		\$ 2,635.64

Card Number xxxx-xxxx-xxxx-0899 DEPARTMENT, TECHNOLOGY

10/25	10/28 558185351	SLEEP INN & SUITES MI1 WILLIAMSBURG MI	\$ 332.76 042591	\$ 0.00	\$ 332.76
10/27	10/28 558185352	AMAZON MKTPL 1W0BK4EY3 AMZN.COM/BILL WA	\$ 106.45 044831	\$ 0.00	\$ 106.45
11/03	11/04 559259644	AMAZON MARK 4P67E8FC3 SEATTLE WA	\$ 162.71 017200	\$ 0.00	\$ 162.71
11/11	11/12 560773168	AMAZON RETA EO2099W53 SEATTLE WA	\$ 187.24 062008	\$ 0.00	\$ 187.24

11/12	11/13 561011796	AMAZON MARK AL1HF2CU3 SEATTLE WA	\$ 16.80 097165	\$ 0.00	
11/13	11/14 561081807	AMAZON MARK LI2SU7XL3 SEATTLE WA	\$ 48.29 085352	\$ 0.00	\$ 48.29
11/19	11/20 562086040	AMAZON MARK IH9G85623 SEATTLE WA	\$ 41.87 045249	\$ 0.00	\$ 41.87
11/24	11/25 562812988	AMAZON MARK QO0274803 SEATTLE WA	\$ 8.46 029013	\$ 0.00	\$ 8.46
11/26	11/27 563291171	AMAZON MARK Z30YD0EO0 SEATTLE WA	\$ 59.00 018360	\$ 0.00	\$ 59.00
11/27	11/27 563291170	AMAZON MKTPL Z361Z11U0 AMZN.COM/BILL WA	\$ 41.87 021458	\$ 0.00	\$ 41.87

TOTAL CREDITS xxxx-xxxx-xxxx-0899 \$ 0.00
TOTAL DEBITS xxxx-xxxx-xxxx-0899 \$ 1,005.45

Card Number xxxx-xxxx-xxxx-5620 GARAGE, BUS

11/06	11/06 559812886	AMAZON.COM 3094N3293 AMZN.COM/BILL WA	\$ 18.98 050216	\$ 0.00	\$ 18.98
11/23	11/25 562813371	SP BUYPARTS.ONLINE FARGO ND	\$ -107.16 000000	\$ 0.00	\$ -107.16
11/25	11/26 563134717	LOWES #00088 ADRIAN MI	\$ 49.20 024039	\$ 2.95	\$ 52.15
11/25	11/26 563134718	LOWES #00088 ADRIAN MI	\$ 72.12 029909	\$ 4.33	\$ 76.45

TOTAL CREDITS xxxx-xxxx-xxxx-5620 \$ -107.16
TOTAL DEBITS xxxx-xxxx-xxxx-5620 \$ 147.58

Card Number xxxx-xxxx-xxxx-7445 PAYABLE, ACCOUNTS

10/28	10/29 558434770	BATTERY WHOLESALE 1002 ADRIAN MI	\$ 49.98 058243	\$ 3.00	\$ 52.98
10/29	10/30 558629544	PY BIGGIES PIZZA ADRIAN MI	\$ 84.00 041842	\$ 0.00	\$ 84.00
11/05	11/06 559812969	REPUBLIC SERVICES TRAS PHOENIX AZ	\$ 1,662.79 069483	\$ 0.00	\$ 1,662.79
11/13	11/14 561081808	OPENAI CHATGPT SUBSCR SAN FRANCISCO CA	\$ 20.00 044725	\$ 0.00	\$ 20.00
11/15	11/18 561587993	IDENTOGO - MI FINGERPR 877-512-6962 MA	\$ 68.25 095695	\$ 0.00	\$ 68.25
11/21	11/22 562602660	TOWING MANCH/AMERICA 1 MANCHESTER MI	\$ 150.00 098183	\$ 0.00	\$ 150.00
11/21	11/22 562602659	LAKESHORE RECYCLING SY ROSEMONT IL	\$ 30.91 000719	\$ 3.09	\$ 34.00

TOTAL CREDITS xxxx-xxxx-xxxx-7445 \$ 0.00
TOTAL DEBITS xxxx-xxxx-xxxx-7445 \$ 2,072.02

STUDENT
REPRESENTATIVE
REPORT

Board Protocol

Board Preparation

All Board of Education members receive information electronically prior to each scheduled meeting. This information may contain reports, background information, recommendations, etc., for study so that the members can come to the meeting prepared to make decisions. Items are brought forward first as discussion items. The discussion item is normally brought back as an action item at the next regular meeting.

Citizen Participation

The responsibility for making decisions rests with the seven elected Board of Education members. The School Board is, however, very interested in hearing from the public. There is a place on the regular meeting agenda for 'Comments from the Audience'. Please follow the guidelines below.

Guidelines for Public Commentary

1. Be recognized by the President of the Board.
2. State your name and address.
3. Present your statement of concern or questions to the Board.
4. Complaints concerning school personnel or students cannot be discussed in an open public meeting unless the individual(s) involved are notified and agree (P.A. 267 of 1967). Such complaints should be forwarded to the Board, in care of the Superintendent, unless the complaint involves the Superintendent, in which case it should be processed through the Board President. An open or closed meeting, according to the wishes of the person(s) involved, will be arranged.
5. In order to adhere to the agenda, the time allocated to any one speaker is limited to five minutes.
6. The Board will hear comments from the audience but may defer any action or response to gather information and study all aspects of the matter brought to their attention.
7. The Onsted Board of Education pledges its courteous attention to those who wish to be heard. In return the Board asks that members of the audience refrain from loud talking and other distractions during the meeting.

REPORTS

November SOM Goal was: RESPECT & RESPONSIBILITY		Description to be placed on certificate
Winners Announced on Next week		
Nominated by	Nominee	
Arnold	Ronan Frederick	Ronan is a mature young man who strives to do his best everyday. He takes his time and turns in quality work
Botte	Bentley Malinowski	Bentley has been progressing well as a 6th grader. He consistently puts forth his best effort each day. Additionally, he demonstrates respect and friendliness by greeting staff members he encounters in the hallway.
Bissot	Jocelyn LaPlante	Jocelyn is an incredibly hard worker in Science class. She consistently demonstrates respect to her classmates and teachers. She is always responsible and prepared for class on a daily basis. Her positive attitude and dedication to her studies make her an exceptional role model for her peers.
Delmotte	Tavin Reid	Tavin has also done a great job showing the three R's in my classroom. Tavin is a good friend and classmate by showing support and helping others around him if they need it. He also does a good job being resilient by asking questions and making sure he is ready and organized for his classes. Tavin is also the last one out of class at the end of everyday picking up garbage on the floors and helping put up chairs that were left down without asking. Tavin always comes to class with a smile on his face and a positive attitude!
Howland	Olivia Lickfelt	
Hildreth	Sylas Johnstone	Sylas shows he is respectful, responsible, and resilient every day. He has shown resilience in continuing to work on code, even when it doesn't behave as anticipated, until he finds a solution.
Hubbard, C.	Zander Springer	Zander Springer consistently demonstrates respect, resilience, and responsibility. What I appreciate the most about him is his kindness in and out of the classroom. His leadership inspires his peers, as he leads by example with a positive attitude and unwavering determination. With his strong sportsmanship and kind personality he easily uplifts others. Zander is building the skills of a true leader and role model and we are proud of the work he is doing.
Hubbard, R.	Carter Holtzbauer	Carter works diligently in class, without offering distractions to others. He has completed all assignments and has displayed kindness and positivity to his peers. Carter also displays leadership daily, while helping and assisting others when needed.
Lilienthal	Grady Barth	Grady demonstrates all 3 R's every day. He is a leader in the classroom and always has a positive attitude. He is always willing to help, even when there is no reward in it for him.
Marsh	Jacob Mattausch	Jacob always has a positive attitude and is great self advocate. He has shown GREAT growth in math class, as well as in Math Foundations. He is also very considerate and supportive of his classmates - showing genuine concern and offering words of encouragement if they are struggling and celebrating their successes with them. He is an asset to his classes, an example to his classmates, and a genuinely kind hearted person.
Martell	Elsie Rutledge	Elsie works hard every day and always has a great attitude. She is part of the Chemistry Challenge and is working on her own to go above and beyond what we do in class.

Mykeloff	Trinity Asher	Trinity has shown a tremendous amount of resilience in band. She has come so far and overcome some difficult times when learning her instrument and now is excelling at her music! I am so proud of the perseverance she has shown and look forward to making music with her for many years to come!!!
Ms Sherman	Autumn Barber	Autumn is proving herself to be a leader at Onsted. She displays integrity everyday, always being reliable and respectful towards students, adults, and herself.
Mrs. Smelser	Bridgett Miller	Bridgett shines as a role model among her peers. Known for her kindness, she goes out of her way to assist others. Her patience is evident in group projects, where she calmly helps her classmates understand and tackle difficult tasks. Her sense of responsibility and respect for people inspires others to stay positive.
Smith, H.	Wesley Garrison	Wesley is the embodiment of The 3 R's at OMS. He is always respectful, responsible and resilient. As a part of the Student Voice team, Wesley leads by example. Wesley is truly an example for all (staff and students alike) to follow.
Thompson	Briella Ross	Briella is a leader through example and always gives her best effort. Regardless, of others actions and attitudes, she continues to work to improve herself.
Westbrook	Connor Hickok	Connor is a calm, insightful student who has demonstrated remarkable growth and maturity.
Wetherby	Izzy (Sophie) King	Sophie is a hard worker and is very attentive in class. She tries her best daily and advocates for herself. She is also extremely helpful and offers her assistance often.
Willhite	Adelynn McConeghy	Adelynn consistently performs above expectations. Her work is complete and creative. She is a model student.

November SOM. Names due to Kipke by November 22nd. SOM announced first week of Dec (ish).

Nominated by	Nominee	Class he/she nominated for:	Comments
Abersold			
Amthor	Jacob Ohlman	US History	Hardworking and respectful young man.
Bates			
Clute	Eli Pustay	Weights & Agility	
Drake	Eve Huber	Ceramics 1	Eve's talent has been an inspiration to the class. Her ceramic flower molds are beautiful and were borrowed by many of her classmates and her teacher.
Frerichs	Serenity Fedd	English Explorations	Serenity's growth from the beginning of the year up until now has been both drastic and amazing. She works so hard to do well on assignments, she asks questions, and she actively pushes her peers to advocate for themselves. She is making strides in becoming an independent, positive young lady.
Helisek	Gavin Lamb	Biology	Gavin has been a model student and an absolute pleasure to have in class.
Howland	Isabel Cundiff	Spanish II	Isabel has demonstrated exceptional dedication to deepening her understanding of Spanish this year, consistently seeking additional opportunities outside of class to dive deeper into language learning. She actively contributes to our cultural discussions in class and has emerged as a leader amongst her peers. Her genuine enthusiasm and the remarkable progress she has made this semester are truly commendable!
Kious	Drake Bosse	World Literature	
Manders	Paige Heslet	Online	Paige is a very hard worker, she always comes to class prepared and ready to get things done.
McNew	Jessiyah Helminiak	Algebra	Jessi is highly motivated, and has excellent study habits. She is very respectful and courteous. She always gets her work done, and often helps other students.
Moore	James Overton	World History	James is always willing to participate in class and ask interesting questions that help drive our class discussions. I appreciate his enthusiasm about history and learning in general.
Mykeloff			
Papenhagen	Grace Teske	Business Technology	Grace is a friendly and cheerful student who arrives daily to class ready to get started. She is trustworthy, knowledgeable and awesome young adult.
Pennington, Cass	Mikala Aitchison	Academic Lab	
Prettyman	Jack Tessier	Basic Foods & Nutrition	Jack is a very polite, hard worker, and is a great team player in the kitchen. It is a pleasure to have him in class.
Schmit	Ruby Helinski	Algebra 2	Ruby will be successful in any path she chooses. Ruby not only displays individual achievement but also thrives with a supportive, collaborative mindset.
Scripter	Brandon Sholar	Geometry	Brandon is a model student, consistent hard worker, and an amazing helper for his peers.
Thompson, D	Kathryn Hurd	Chemistry	Kathryn has been very helpful to other students in class. Her expressions have been more open and friendly, making her more approachable.
Thompson, H	Nick Holmes	American Literature	Nick has improved his effort considerably and works to understand the material for himself, not the grade. He asks clarifying questions and focuses on the task at hand.
Walters	Kaelyn Moore	World History	As described by her peers - Kaelyn is a hard working student and puts 100% effort into everything she does.

Overview

Reach ⓘ
70.3K ↑ 562.3%

Content interactions ⓘ
17.2K ↑ 1.8K%

Followers ⓘ
Lifetime
2.5K

Link clicks ⓘ
138 ↑ 1.4K%

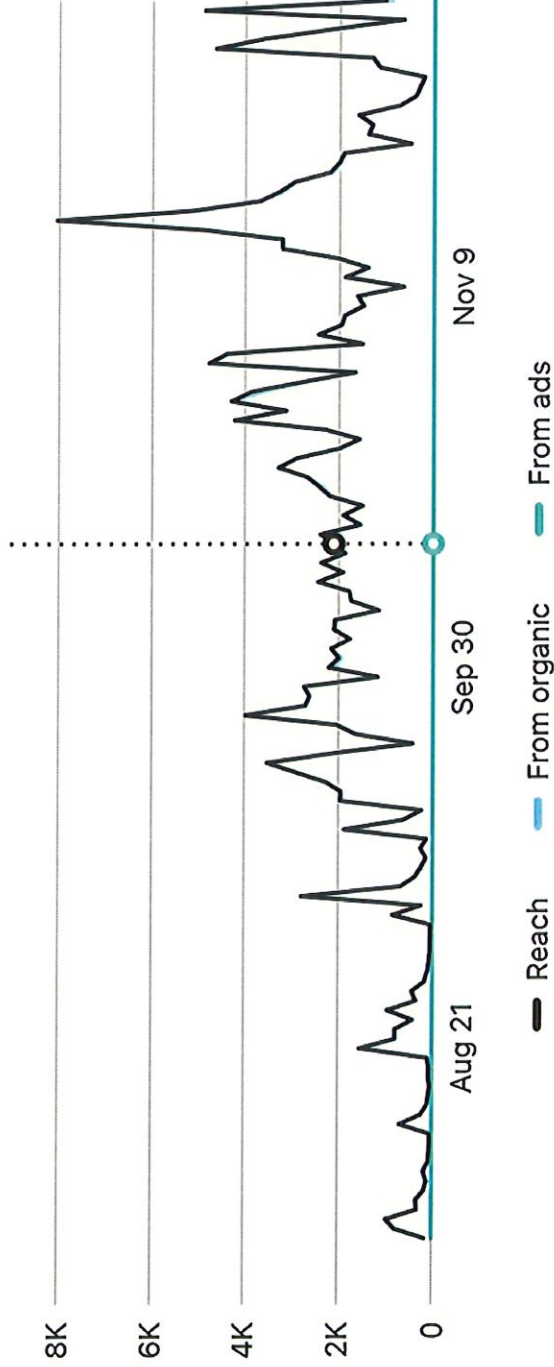

Reach breakdown

Total
70,327 ↑ 562.3%

From organic
70,327 ↑ 562.3%

From ads
0 0%

Audience

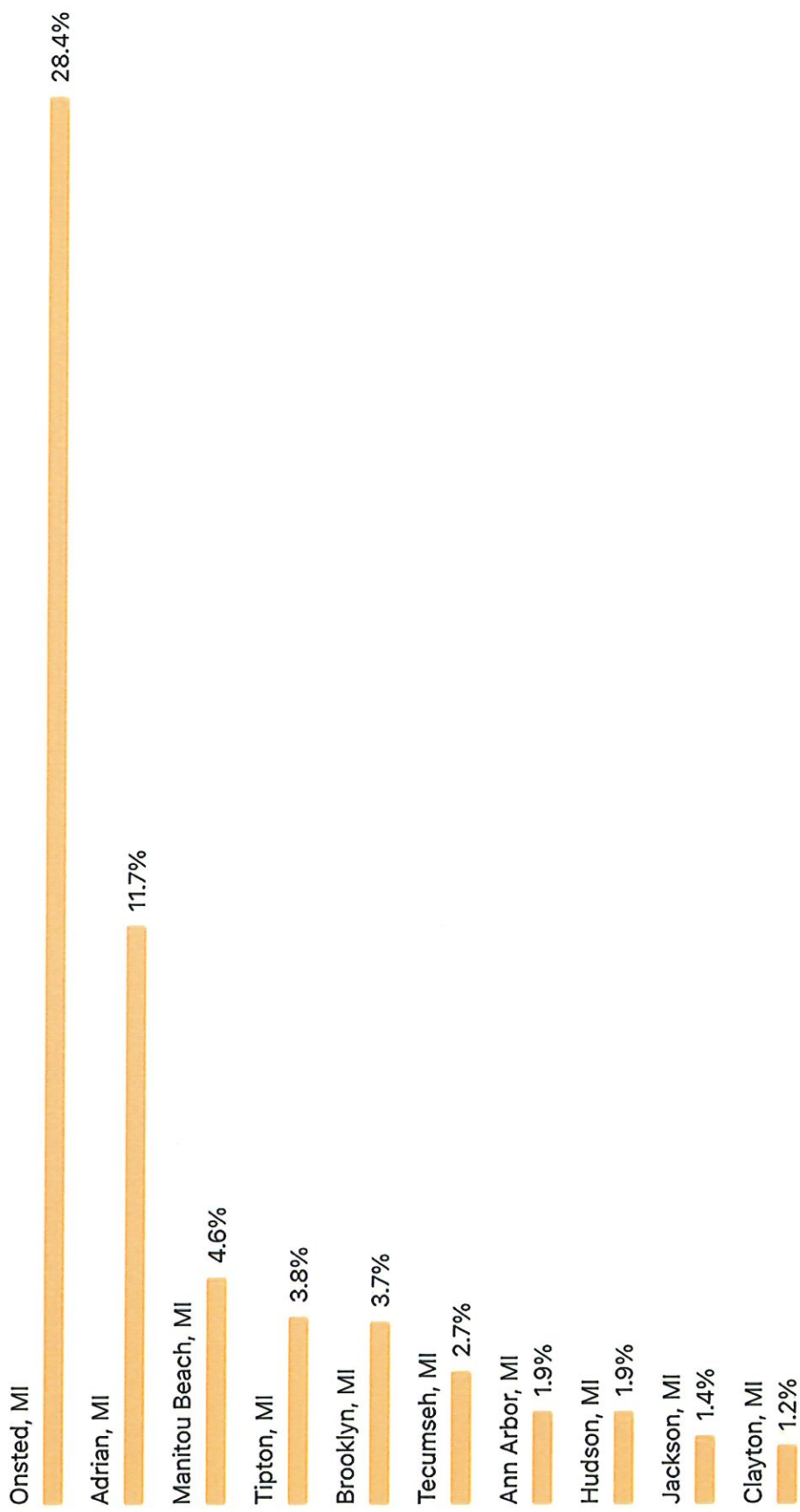

Followers

Audience breakdown

Sep 16 – Dec 9

Net follows ⓘ

209 ↑ 386%

Follows ⓘ

258 ↑ 309.5%

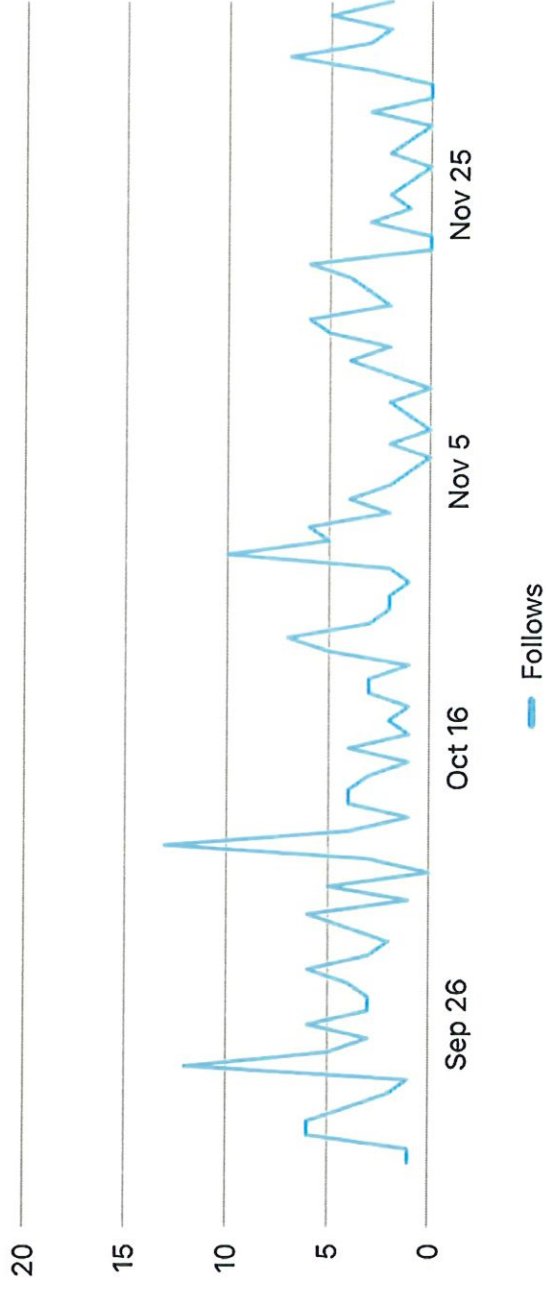

The Lenawee County Parent Advisory Committee Presents:

Board of Education Presentation Summary of the Inclusion Champion Awards

December 16, 2024



Parent Advisory Committee Purpose:

- The Michigan Administrative Rules for Special Education (MARSE) requires each intermediate school district (ISD) establish a Parent Advisory Committee (PAC).
- A PAC is made up of parents of children with disabilities.
- Each local school district within the ISD has at least one parent as a member.
- The PAC gives advice and feedback, from a parent perspective, on the special education programs, services, and policies provided by the ISD.
- The PAC also serves as liaisons between the ISD and other parents within the school district.

PAC activities during monthly meetings:

- Participates in reviewing the ISD Plan which details how special education programs/services are provided within the school district.
- Review and provide advice on requests from the district for temporary deviation from any specific rules in the Michigan Administrative Rules for Special Education (MARSE).
- Stays current/provides input on topics and changes on special education issues.
- Invites guest speakers and shares information from statewide agencies and programs to help educate and inform parents.
- Serves as a resource of information and the voice for other parents and families in the district.

Officer Matt Swirple ~ School Resource Officer

“He is the first staff member we see every morning and the last every afternoon. He always greets us with a smile and takes time to acknowledge each child which I think is amazing for the kiddos because they feel seen, appreciated and safe. He's turned frowns upside down many times by treating the kids like his own family. They go to and from school feeling important and I think he deserves to be recognized for the outstanding job he's doing.”

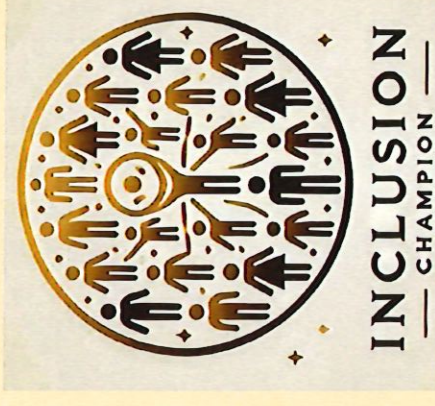

Officer Matt Swirple ~ School Resource Officer

“Being inclusive, begins with first being safe. Every morning officer Matt approaches each child with a smile, greeting, high five, you name it. He is aware of every child needing recognition for coming to school eager to learn on a safe and inclusive setting. This cannot be overlooked, as he sets the tone for each child, each day. He’s taken time to hold students hands and cross who are very young in age and may be afraid to cross the road. He sets an example of how authority figures are servant leaders of our community. Great job!”

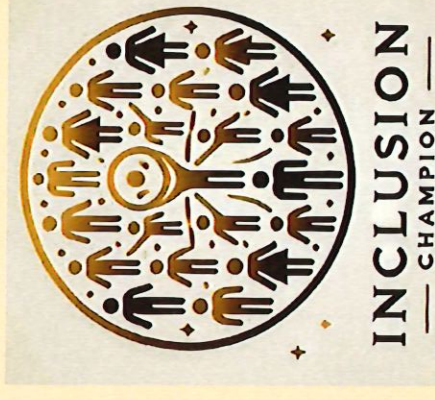

Ashley Germain - GSRP Teacher

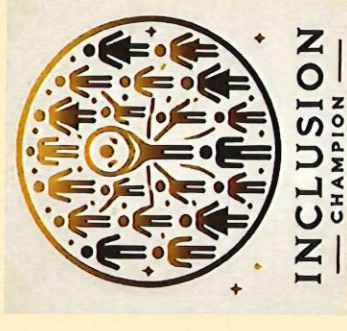

“After my child was kicked out of preschool last fall due to toileting needs, I was terrified to send them to anywhere. We had done everything our prior preschool had asked, only to be told their lives didn’t matter to them. My children are both diagnosed with ASD, severe speech/language disorders, sensory processing disorder, and ADHD. After this experience, they regressed, became terrified of the bathroom, and lost what little words they had. Next, we began a new journey with Mrs. Germain and Mrs. Robbins, who are truly the epitome of what inclusion, love and acceptance is all about. They meet each child’s exact needs, show so much patience and most of all just love them. My boys have exploded in language and playing with peers. They can’t wait to go to school every single day. They run to their teacher smiling as they look back at me saying ‘bye mom’. All teachers need to be more like Mrs. Germain. Maybe our world would become a better place where students would flourish, so that everyone including other students could become more humble, open, and kind to those who are different.”

Mr. Matthew Rivera ~ 5th Grade Teacher

A KIND AND COMPASSIONATE 5th grade teacher

received **SIX** nominations. This is the most we received for any individual being nominated for this award in Lenawee County.

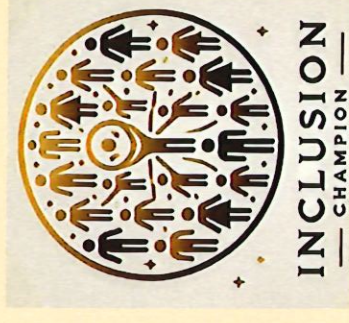

“Before 5th grade, our son would regularly say that he didn't like school. After his very first day of class with Mr. Rivera, his whole attitude had changed. He no longer wanted to settle for anything other than an A+. He worked so hard and finally got his A+, 100%, no questions missed. He was so proud of himself and we were so proud of him as well. I had volunteered in Mr. Rivera's class many times and it was easy to see that Mr. Rivera truly cared for each and every one of his students and made the entire class feel like a family. As for us in our home, our son's whole outlook on school changed with Mr. Rivera. He continues to strive for straight A's in 6th grade this year and actually enjoys going to school. Mr. Rivera had the greatest impact on his academic growth, as well as helping him grow socially. At the end of the school year last year, my child was more than well prepared to move onto his next journey through middle school. We can't thank Mr. Rivera enough for his impact on our son, and on us as parents. By far the best teacher we will have. Any incoming 5th graders going forward would be lucky to have Mr. Rivera. He is kind, caring, and truly loves what he does. He is more than deserving of this award.”

“Mr. Rivera intentionally stressed the importance of treating ALL kids with respect day in and day out. He created an open environment where kids felt safe telling him if they were uncomfortable and he stood strong against bullying. He taught kids to stick together and look out for each other. Mr. Rivera’s students were so inspired by him that they made #TeamRivera signs and came to the games he coached to sit in the stands together. The kids who did this represented kids from a variety of background and ability levels.”

“Mr. Rivera helped my son so much last year. He went above and beyond it make sure my son understood his assignments/homework and even came in early to help him. He boosted my son’s confidence and lowered his anxiety by being someone who truly cared about him. On weekends Mr. Rivera would go to his student’s games and cheer them on. He is a remarkable human being. I’m not sure I’ve ever met a more deserving human being.”

“He is the kindest and most genuine human. He makes sure that everyone feels welcome and as if they are in a safe space. He encouraged my son every day and made him feel like a rock star.”

“His passion for each of his students is astounding. On a personal level, for having a child on the spectrum, his compassion and understanding have been immensely appreciated and the communication he provides makes me feel more secure that my kid is not just going to “get by”, but will soar this year. Parents in the community have shown in the past and recent how involved he is in his students lives even when he is “off the clock”, he attends sport events and other activities his class is in. The level of care in his weekly emails brings tears to my eyes regularly, because you can *feel* the passion he has in his soul as an educator. Onsted is SO blessed to have him help raising our village.”

“My son had Mr. Rivera for 5th grade last year and right off the bat, he made it known that he wanted to inspire the kids to believe in themselves and push them to do their best. He also stressed that bullying would not be tolerated. My son is autistic and I have always worried about him getting teased because he is a little different. I didn't have to worry about that when he was with Mr. Rivera. He pushed my son to try more advanced math and helped him realize that learning is endless. He created an environment where kids could see their potential and were able to explore more in their interests. When your kid truly enjoys going to class every day and you know he's safe and comfortable, it speaks volumes to the kind of teacher he is. His weekly emails were always positive and wanting to help the kids in any way he could.”

Onsted Community Schools
Reproductive Health Advisory Board Agenda
12-9-24 | 5:30 pm | Onsted Board Office Conference Room

Committee Members:	<p>Alaina Ellison Co-Chair/ parent Nicole Brown, RN- Sex Education Supervisor/ parent Sharon Upp- ES Counselor Brad Maska- ES Teacher Jori Monnich- Parent Carrie Pennington- HS Counselor Victoria Prettyman- HS Teacher Jessica Hallenbeck- Parent/Community Health Professional Craig McMichael- Pastor Gateway Community Church Ashley Kish- Parent (attended virtually) Alicia Ross- Parent Jeff Thompson- MS Teacher Courtney Chamberlain Co-Chair/ parent Rhonda Hubbard- MS Teacher Rachel Pangborn- Parent/Community Health Professional Jace Ellison- HS Student Representative</p>
Date & Time:	12-9-24 5:30-6:30 pm- OCS Board Office
Facilitator: Note taker: Timekeeper:	Alaina Ellison Courtney Chamberlain
Purpose of Meeting:	<p>To Provide Updates from previous meeting and to decide on action items with goal being to submit an update at the next OCS board meeting.</p> <p>The SEAB is responsible for: • Establishing program goals and objectives for pupil knowledge and skills that are likely to reduce the rates of sex, pregnancy, and STIs. • Reviewing and recommending materials and methods of instruction to the local school board, taking into consideration the district’s needs, demographics, and trends including, but not limited to, teenage pregnancy rates, STI rates, and incidents of sexual violence and harassment. • Evaluating, measuring, and reporting the attainment of program goals and objectives and making the resulting report available to parents in the district at least once every two years. (§380.1507)</p>

Time Allotted	Task/Activity (what & how) and Notes	Facilitator	Resources
20	Welcome Introductions Review Documents	Alaina	Previous Agenda/Notes

	<ul style="list-style-type: none"> ● Legal obligations ● Data- MiPhy ● Goals <ul style="list-style-type: none"> ○ To enhance parent and family engagement in efforts to improve Michigan Profile for Healthy Youth (MiPHY) data outcomes. Our team will share current MiPHY data with families and establish clear channels for addressing their questions and concerns. This data will be reviewed in two years to evaluate progress and identify opportunities for further support and collaboration with families, as needed. ● Sexual Health Education Handbook 		
60	<p>Review Action Items from previous Meeting</p> <ul style="list-style-type: none"> ● Student Representatives <ul style="list-style-type: none"> ○ This is always difficult to find representation as this is a sensitive subject ● Age Appropriateness- move 7th to 6th <ul style="list-style-type: none"> ○ No discussion, we are unsure if this would be effective or not ● Grouping (boys & girls) <ul style="list-style-type: none"> ○ OMS will survey students at the end of this year's lessons to determine if they feel like being together for the relationship part would be helpful. 	Alaina	
20	<p>Action Items</p> <ul style="list-style-type: none"> ● Board Approval (next Board meeting is December 16) <ul style="list-style-type: none"> ○ This would be #1 of 2 public board hearings if we need approval <ul style="list-style-type: none"> ■ We do not have any curriculum that needs approval, we only need to report on our goals 	Alaina	

EMPLOYMENT

DISCUSSION

Dear Members of the School Board,

I am requesting approval to use funds from our access fund balance to replace two ovens in the Food Service department. Currently, the ovens we have are taking over 30 minutes to reach temperature, which delays meal preparation and affects food quality. Additionally, they heat unevenly, causing food to burn and resulting in wasted resources.

Replacing these ovens will help ensure that we can prepare meals efficiently and maintain the quality of food served to our students. This investment will improve both the operational flow of the kitchen and the overall dining experience for our students.

Thank you for your time and consideration.

Sincerely,

Amber Starnes



Food Service Equipment

Phone: (800) 632-4572 | Fax: (269) 795-1189



11/26/2024

TW132625

Quote

<p>To: Onsted Community Schools #2135 Amber Starners 10109 Slee Rd Onstead, MI 49265 517-467-5500 (Contact) starnes.a@onstedschools.us</p>	<p>From: HPS Tammy Wilcox Customer Service Representative 3275 N M-37 Highway Middleville, MI 49333 (800) 632-4572 (Contact) twilcox@hpsnet.com</p>
--	---

Ship to: Onsted Community Schools #2135
10109 Slee Rd
Onstead, MI 49265-

Item	Qty	Description	Sell	Sell Total
1	2 ea	CONVECTION OVEN, GAS Blodgett (Middleby) DFG-100 DBL-K12 Convection Oven, gas, double-deck, standard depth, capacity (5) 18" x 26" pans per compartment, Artisan touchscreen controls with meat probe, 2-speed fan, Oleophobic baking compartment liner, interior light, simultaneous operated with dual pane thermal glass windows sealed in stainless steel door frames and ergonomically friendly curved aluminum door handle, stainless steel front, sides & top, 6" stainless steel legs, flue connector, (2) 1/2 HP, 55,000 BTU each, cETL, NSF, CE Dimensions 70.63(h) x 38.25(w) x 36.88(d)	\$22,689.87	\$45,379.74
	2 ea	5 year parts, labor and door warranty (parts only)		
	2 ea	Natural gas		
	4 ea	115v/60/1-ph, 6.0 amps, 1/2 hp, 2-wire with ground, NEMA 5-15P (per deck), standard		
	2 ea	SSI-M Top Oven: Solid State infinite control with 60 min. manual timer		
	2 ea	SSI-M Bottom Oven: Solid State infinite control with 60 min. manual timer		
	2 ea	Draft diverter or Draft hood must be selected below		
	2 ea	Draft diverter		
	2 st	6" legs, adjustable, stainless steel (set), standard		
		<i>NOTE: This is the replacement for your existing unit with Serial #082902RA035T</i>		
	1 ea	<i>NOTE: 6" Legs are standard but if you would like casters, please let me know and I will have them priced out.</i>		
	1 ea	FRT Free Freight Charges to a loading dock		
	1 ea	LG Additional charges for a lift gate delivery if there is no loading dock available to unload off of delivery truck.	\$180.00	\$180.00
		Weight: 2590 lbs total		
			Extended Total:	\$45,559.74

Thank you for the opportunity to quote the above item(s). If you have any questions, need more information or would like to place an order, please call me at the HPS office.

Tammy

HPS Customer Service
twilcox@hpsnet.com

Invoices paid with credit card are subject to a 3% processing fee*

Pricing does not include freight charges unless noted otherwise.

LIMITED ACCESS FEE & FUEL SURCHARGES MAY APPLY AT TIME OF INVOICE.

PRICING SUBJECT TO MANUFACTURE'S PRICE INCREASES.

Please verify all Dimensions and any Voltage & Phase or Gas types before placing an order. Verify equipment will fit through all doorways and sufficient turning room exists at all points along route to final destination inside building.

PRICE INCREASES / AVAILABILITY / LEAD TIMES

This quote is based upon the manufacturer's current published price list.

Freight delays and/or periodic shortages of raw materials and parts due to the worldwide pandemic may result in extended lead times and increased cost after your order is placed, which is out of our control.

HPS cannot be held responsible for any manufacturer cost increases or production delays to orders. We will communicate with you as soon as we are notified should any changes occur.

Important Information about your Delivery!

NOTE: If facility will be receiving delivery of order than they will be responsible for the below. If order is being sent to an Installer to receive, than they will be responsible for the below.

You are responsible for:

- Removing the shipment from the truck unless a lift gate delivery is required to get equipment to ground level (Must be noted on PO and there will be an additional charge for lift gate service)
- Bringing it into your location (Delivery drivers do not bring equipment into building)
- Noting damaged or missing items on the carrier's delivery receipt

Upon inspection, if any piece of the shipment is damaged or missing:

- Note it clearly on the delivery receipt before signing (ie - "missing 3 pieces", "holes in packaging", "multiple dents on table", etc).
- Keep your copy of the delivery receipt
- Contact us within 1 business day
- Keep the damaged packing materials for inspection
- Take pictures of the damaged items and packaging

If you do not make note of these issues in any way on the delivery receipt, we cannot guarantee any compensation for damaged or missing items. By signing your name on the delivery receipt without declaring these exceptions, you are stating that you have received your shipment in acceptable condition.

Acceptance: _____ Date: _____
Printed Name: _____

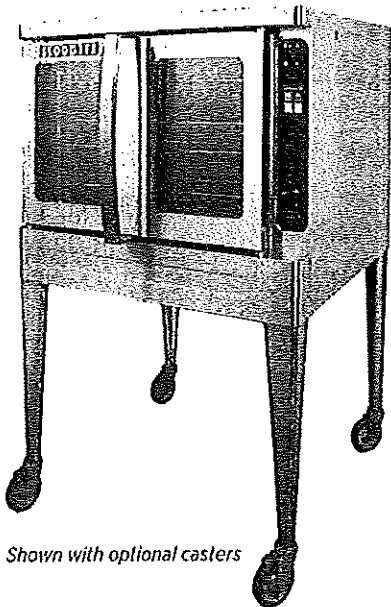
BLODGETT**DFG-100****Full-Size, Standard Depth
Dual Flow Gas Convection Oven**

Shown with optional casters

**OPTIONS AND ACCESSORIES
(AT ADDITIONAL CHARGE)**

- **Legs, casters & stands**
 - 6" (152mm) seismic legs
 - 6" (152mm) casters
 - 4" (102mm) low profile casters (double only)
 - 25" (635mm) stainless steel stand w/rack guides
 - 29" (737mm) stainless steel, fully welded open stand with pan supports
- **Gas hose w/quick disconnect restraining device**
 - 48" (1219mm) hose
 - 36" (914mm) hose
- SSI-M - Solid state infinite control w/manual timer
- Stainless steel oven liner
- Extra oven racks
- Stainless steel solid back panel
- Gas manifold (for double sections)
- Prison package (includes security control panel and stainless steel back)
- Flue connector

**OPTIONS AND ACCESSORIES
(AT NO ADDITIONAL CHARGE)**

- Solid stainless steel doors

Project _____

Item No. _____

Quantity _____

Standard depth baking compartment - accepts five 18" x 26" standard full-size baking pans in left-to-right positions.

All data is shown per oven section, unless otherwise indicated. Refer to operator manual specification chart for listed model names.

EXTERIOR CONSTRUCTION

- Stainless steel front, top, and sides
- Dual pane thermal glass windows sealed in stainless steel door frames
- Ergonomically friendly, curved aluminum door handle with simultaneous door operation
- Triple-mounted pressure lock door design with turnbuckle assembly
- Modular slide out front control panel for easy cleaning
- Solid mineral fiber insulation at top, back, sides and bottom

INTERIOR CONSTRUCTION

- Full angle-iron frame
- Easy to clean Oleophobic baking compartment liner (14 gauge)
- Aluminized steel combustion chamber
- Dual inlet blower wheel
- Five chrome-plated racks, eleven rack positions with a minimum of 1-5/8" (41mm) spacing

OPERATION

- Dual Flow Gas system combines direct and indirect heat
- Electronic spark ignition control system
- Removable dual tube burners
- Pressure regulator
- Manual gas service cut-off switch located on the front of the control panel
- Air mixers with adjustable air shutters
- Solid state thermostat with temperature control range of 200°F (93°C) to 500°F (260°C)
- Two speed fan motor
- 1/2 horsepower blower motor with automatic thermal overload protection
- Control area cooling fan
- Interior oven lights

STANDARD FEATURES

- Artisan Touchscreen Control with meat probe allows for Manual Cooking, Recipe Cooking, Cook and Hold, Core Probe Cooking, Fan Delay, and Fan Pulse.
- 25" (635mm) adjustable stainless steel legs (for single units)
- 6" (152mm) adjustable stainless steel legs (for double sections)
- Draft diverter or draft hood for venting (select one)
- Three year parts and two year labor warranty
- Five year limited oven door warranty*
- * For all international markets, contact your

* For all international markets, contact your local distributor.

NOTE: The company reserves the right to make substitutions of components without prior notice



www.blodgett.com

42 Allen Martin Drive, Essex Junction, VT 05452
Phone: (802) 658-6600 | Fax: (802) 864-0183



DFG-100

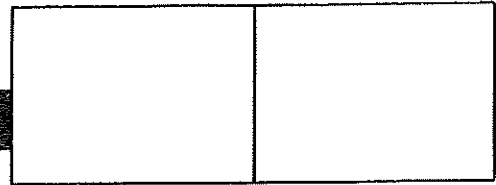

APPROVAL/STAMP

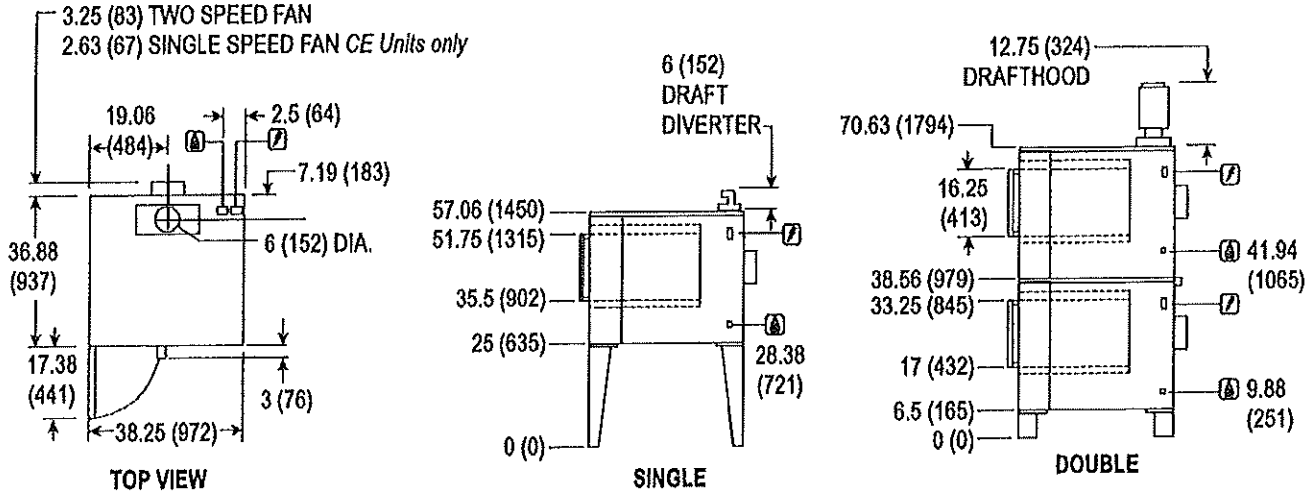

DIMENSIONS ARE IN INCHES (MM)

SHORT FORM SPECIFICATIONS Provide Blodgett full-size, bakery depth convection oven model DFG-100, (single/double) compartment. Each compartment shall have Oleophobic 14 gauge steel liner and shall accept five 18" x 26" standard full-size bake pans in left-to-right or front-to-back positions. Stainless steel front, top and sides. Doors shall be (solid stainless steel/dual pane thermal glass windows) with single curved aluminum door handle and simultaneous operation. Unit shall be gas heated with electronic spark ignition and shall cook by means of a direct fired system with a gas shutoff switch on the front of the control panel. Air in baking chamber distributed by single inlet blower wheel powered by a two-speed, 1/2 HP motor with thermal overload protection. Each chamber shall be fitted with two halogen lamps, and five chrome-plated removable racks. Control panel shall be recessed with Artisan Touchscreen Control allowing manual and recipe cooking, cook and hold, probe cooking, fan delay, and fan pulse. Provide three years parts, two year labor and five year door warranty. Provide options and accessories as indicated.

DIMENSIONS

Floor space	38-1/4" (972mm) W x 36-7/8" (937mm) D
Interior	29" (737mm) W x 20" (508mm) H x 24-1/4" (616mm) D
If oven is on casters	
Single	Add 4-1/2" (114mm) to height
Double	Height dimensions remain the same
Double Low Profile	Subtract 2.5" (64mm) from all height dimensions

PRODUCT CLEARANCE

From combustible and non-combustible construction

Oven sides	2" (51mm)
Oven back	0" (0mm)

MINIMUM ENTRY CLEARANCE

Uncrated	32-1/16" (814mm)
Crated	37-1/2" (953mm)

SHIPPING INFORMATION

Approx. Weight

Single	600 lbs. (273 kg)
Double	1295 lbs. (589 kg)

Crate Size

37-1/2" (952mm) x 43-1/2" (1105mm) x 51-3/4" (1315mm)
(2 crates required for double)

GAS SUPPLY (per section)

	3/4" NPT
Inlet Pressure	
Natural Gas	7.0" W.C. min. - 10.5" W.C. max.
Propane	11.0" W.C. min. - 13.0" W.C. max.
Manifold Pressure	
Natural Gas	3.5" W.C.
Propane	10" W.C.

MAXIMUM INPUT

55,000 BTU/hr (16.2 Kw) per oven section

POWER SUPPLY

115 VAC, 1 phase, 6 Amp, 60 Hz., 2-wire with ground, 1/2 H.P., 2 speed motor, 1120 and 1710 RPM
6' (1.8m) electric cord set furnished on 115 VAC ovens only.

SUPERINTENDENT REPORT

2024-2025 Fall FTE Count

Onsted Community Schools (46110)

Audit Status: Unaudited (DS4061)

Updated By on

Audited By:

Special Education

Acct	Description	Sec53a	Resident Sec52	Non-Resident Sec52	Total
110	Programs for Mild Cognitive Impairment	0.00	0.00	0.00	0.00
120	Programs for Moderate Cognitive Impairment	0.00	0.00	0.00	0.00
130	Programs for Severe Cognitive Impairment	0.00	0.00	0.00	0.00
140	Programs for Emotional Impairment	0.00	1.28	2.01	3.29
150	Programs for Learning Disabled	0.00	0.00	0.00	0.00
160	Programs for Hearing Impairment	0.00	0.00	0.00	0.00
170	Programs for Visual Impairment	0.00	0.00	0.00	0.00
180	Programs for Physical or Other Health Impairment	0.00	0.00	0.00	0.00
190	Programs for Severe Multiple Impairment	0.00	0.00	0.00	0.00
191	Early Childhood Special Education (Classroom) Program	0.00	0.00	0.00	0.00
192	Programs for Severe Language Impairment	0.00	0.00	0.00	0.00
193	Programs for Autism Spectrum Disorder	0.00	0.00	0.00	0.00
194	Elementary or Secondary-Level Resource Program	0.00	17.95	6.24	24.19
270	Early Childhood Special Education Services	0.00	0.00	0.40	0.40
Special Education Total		0.00	19.23	8.65	27.88

2024-2025 Fall FTE Count

Onsted Community Schools (46110)

Audit Status: Unaudited (DS4061)

Updated By on

Audited By:

K-12 Pupil Membership (FTE) in General Education

Grade	FTE w/o Graded Alt Ed	FTE Graded Alt Ed Only	Total
Kindergarten	98.83	0.00	98.83
First Grade	84.68	0.00	84.68
Second Grade	80.69	0.00	80.69
Third Grade	96.13	0.00	96.13
Fourth Grade	77.87	0.00	77.87
Fifth Grade	87.83	0.00	87.83
Sixth Grade	76.54	0.00	76.54
Seventh Grade	78.33	0.00	78.33
Eighth Grade	79.13	0.00	79.13
Ninth Grade	83.67	0.00	83.67
Tenth Grade	110.62	0.00	110.62
Eleventh Grade	89.14	0.00	89.14
Twelfth Grade	86.23	0.00	86.23
Special Education Transition	0.00	0.00	0.00
Alternative Education	0.00	0.00	0.00
Total General Ed	1129.69	0.00	1129.69

2024-2025 Fall FTE Count

Onsted Community Schools (46110)

Audit Status: Unaudited (DS4061)

Updated By on

Audited By:

Additional Information on K-12 Pupils

Grade	Special Education	General Education	Total
Non-public resident of district	0.00	1.75	1.75
Non-resident pupils without release	0.00	0.00	0.00
Special Ed and General Ed FTE (Sec. 24)	0.00	0.00	0.00

Residency Related Information

District	Non K-12 District		Section 105/105C Schools of Choice		Non-Public Non-Resident		All Other		Total
	Spec. Ed	Gen. Ed	Spec. Ed	Gen. Ed	Spec. Ed	Gen. Ed	Spec. Ed	Gen. Ed	
30030 Jonesville Community Schools	0.00	0.00	0.00	2.00	0.00	0.00	0.00	0.00	2.00
30050 North Adams-Jerome Public Schools	0.00	0.00	0.14	4.86	0.00	0.00	0.00	2.00	7.00
38040 Columbia School District	0.00	0.00	1.26	32.74	0.00	0.00	0.40	0.00	34.40
38120 Michigan Center School District	0.00	0.00	0.08	2.92	0.00	0.00	0.00	0.00	3.00
38130 Napoleon Community Schools	0.00	0.00	0.14	1.86	0.00	0.00	0.00	0.00	2.00
38170 Jackson Public Schools	0.00	0.00	0.14	0.86	0.00	0.00	0.00	0.00	1.00
46010 Adrian Public Schools	0.00	0.00	2.64	110.36	0.00	0.00	0.00	1.00	114.00
46020 Addison Community Schools	0.00	0.00	2.31	90.69	0.00	0.00	0.00	0.00	93.00
46060 Clinton Community Schools	0.00	0.00	0.38	6.62	0.00	0.00	0.00	0.00	7.00
46080 Hudson Area Schools	0.00	0.00	0.72	10.70	0.00	0.00	0.00	0.00	11.42
46100 Morenci Area Schools	0.00	0.00	0.00	1.00	0.00	0.00	0.00	0.00	1.00
46130 Sand Creek Community Schools	0.00	0.00	0.00	2.00	0.00	0.00	0.00	0.00	2.00
46140 Tecumseh Public Schools	0.00	0.00	0.44	25.56	0.00	0.00	0.00	0.00	26.00
Total	0.00	0.00	8.25	292.17	0.00	0.00	0.40	3.00	303.82

2024-2025 Fall FTE Count

Onsted Community Schools (46110)

Audit Status: Unaudited (DS4061)

Updated By on

Audited By:

Adult Education Participants (July Count Date)

Description	--- Under 20 ---			--- 20 and Over ---			Total
	w/GED	w/Diploma	w/o GED/Diploma	w/GED	w/Diploma	w/o GED/Diploma	
Total							0

2024-2025 Fall FTE Count

Onsted Community Schools (46110)

Audit Status: Unaudited (DS4061)

Updated By on

Audited By:

Adult Education Participants (September Count Date)

Description	--- Under 20 ---			--- 20 and Over ---			Total
	w/GED	w/Diploma	w/o GED/Diploma	w/GED	w/Diploma	w/o GED/Diploma	
Total							0

Total Adult Ed Participants this Submission

July Participants for Fall 2024-2025	0
September Participants for Fall 2024-2025	0
Total Adult Education Count for Fall 2024-2025	0

Summary of Membership

Total Special Education	27.88
Subtract: Non Resident Special Education without Release Form	0.00
Total Adjusted Special Education Count	27.88
K-12 Pupils	1,129.69
Subtract: Non Resident General Education without Release Form	0.00
Total Adjusted K-12 Membership Count	1,129.69
Total Adjusted K-12 & Special Education FTE	1,157.57

Section 25 Net Adjustments

Special Education Section 25 Adjustments	0.00
General Education Section 25 Adjustments	0.00
Total Section 25 Adjustments	0.00

2023-2024 Fall FTE Count

Onsted Community Schools (46110)

Updated By Stephanie Roberts on 4/21/2024 8:31:56 PM

Audit Status: Audited (DS4120)

Audited By: Stephanie Roberts

Special Education

Acct	Description	Sec53a	Resident Sec52	Non-Resident Sec52	Total
110	Programs for Mild Cognitive Impairment	0.00	0.00	0.31	0.31
120	Programs for Moderate Cognitive Impairment	0.00	0.00	0.00	0.00
130	Programs for Severe Cognitive Impairment	0.00	0.00	0.00	0.00
140	Programs for Emotional Impairment	0.00	1.93	1.41	3.34
150	Programs for Learning Disabled	0.00	0.00	0.00	0.00
160	Programs for Hearing Impairment	0.00	0.00	0.00	0.00
170	Programs for Visual Impairment	0.00	0.00	0.00	0.00
180	Programs for Physical or Other Health Impairment	0.00	0.00	0.00	0.00
190	Programs for Severe Multiple Impairment	0.00	0.00	0.00	0.00
191	Early Childhood Special Education (Classroom) Program	0.00	0.00	0.00	0.00
192	Programs for Severe Language Impairment	0.00	0.00	0.00	0.00
193	Programs for Autism Spectrum Disorder	0.00	0.00	0.00	0.00
194	Elementary or Secondary-Level Resource Program	0.00	16.57	6.48	23.05
270	Early Childhood Special Education Services	0.00	0.00	0.00	0.00
Special Education Total		0.00	18.50	8.20	26.70

2023-2024 Fall FTE Count

Onsted Community Schools (46110)

Updated By Stephanie Roberts on 4/21/2024 8:31:56 PM

Audit Status: Audited (DS4120)

Audited By: Stephanie Roberts

K-12 Pupil Membership (FTE) in General Education

Grade	FTE w/o Graded Alt Ed	FTE Graded Alt Ed Only	Total
Kindergarten	99.51	0.00	99.51
First Grade	79.44	0.00	79.44
Second Grade	94.98	0.00	94.98
Third Grade	77.34	0.00	77.34
Fourth Grade	87.42	0.00	87.42
Fifth Grade	81.15	0.00	81.15
Sixth Grade	78.31	0.00	78.31
Seventh Grade	83.16	0.00	83.16
Eighth Grade	80.99	0.00	80.99
Ninth Grade	117.90	0.00	117.90
Tenth Grade	93.76	0.00	93.76
Eleventh Grade	101.98	0.00	101.98
Twelfth Grade	80.42	0.00	80.42
Special Education Transition	0.00	0.00	0.00
Alternative Education	0.00	0.00	0.00
Total General Ed	1156.36	0.00	1156.36

2023-2024 Fall FTE Count

Onsted Community Schools (46110)

Updated By Stephanie Roberts on 4/21/2024 8:31:56 PM

Audit Status: Audited (DS4120)

Audited By: Stephanie Roberts

Additional Information on K-12 Pupils

Grade	Special Education	General Education	Total
Non-public resident of district	0.00	1.75	1.75
Non-resident pupils without release	0.00	0.00	0.00
Special Ed and General Ed FTE (Sec. 24)	0.00	0.00	0.00

Residency Related Information

District	Non K-12 District		Section 105/105C Schools of Choice		Non-Public Non-Resident		All Other		Total
	Spec. Ed	Gen. Ed	Spec. Ed	Gen. Ed	Spec. Ed	Gen. Ed	Spec. Ed	Gen. Ed	
30030 Jonesville Community Schools	0.00	0.00	0.00	1.00	0.00	0.00	0.00	0.00	1.00
30050 North Adams-Jerome Public Schools	0.00	0.00	0.14	3.86	0.00	0.00	0.00	0.00	4.00
38040 Columbia School District	0.00	0.00	1.30	36.70	0.00	0.00	0.00	0.00	38.00
38120 Michigan Center School District	0.00	0.00	0.08	1.92	0.00	0.00	0.00	0.00	2.00
46010 Adrian Public Schools	0.00	0.00	2.60	101.71	0.00	0.00	0.16	3.84	108.31
46020 Addison Community Schools	0.00	0.00	2.32	93.41	0.00	0.00	0.00	0.00	95.73
46060 Clinton Community Schools	0.00	0.00	0.28	7.72	0.00	0.00	0.00	0.00	8.00
46080 Hudson Area Schools	0.00	0.00	0.34	10.66	0.00	0.00	0.00	0.00	11.00
46090 Madison School District (Lenawee)	0.00	0.00	0.00	1.00	0.00	0.00	0.00	0.00	1.00
46100 Morenci Area Schools	0.00	0.00	0.00	1.00	0.00	0.00	0.00	0.00	1.00
46110 Onsted Community Schools	0.00	0.00	0.00	0.00	0.00	0.00	0.00	0.00	0.00
46130 Sand Creek Community Schools	0.00	0.00	0.00	2.00	0.00	0.00	0.00	0.00	2.00
46140 Tecumseh Public Schools	0.00	0.00	0.98	29.02	0.00	0.00	0.00	1.00	31.00
Total	0.00	0.00	8.04	290.00	0.00	0.00	0.16	4.84	303.04

2023-2024 Fall FTE Count

Onsted Community Schools (46110)

Updated By Stephanie Roberts on 4/21/2024 8:31:56 PM

Audit Status: Audited (DS4120)

Audited By: Stephanie Roberts

Adult Education Participants (July Count Date)

Description	--- Under 20 ---			--- 20 and Over ---			Total
	w/GED	w/Diploma	w/o GED/Diploma	w/GED	w/Diploma	w/o GED/Diploma	
Total							0

2023-2024 Fall FTE Count

Onsted Community Schools (46110)

Updated By Stephanie Roberts on 4/21/2024 8:31:56 PM

Audit Status: Audited (DS4120)

Audited By: Stephanie Roberts

Adult Education Participants (September Count Date)

Description	--- Under 20 ---			--- 20 and Over ---			Total
	w/GED	w/Diploma	w/o GED/Diploma	w/GED	w/Diploma	w/o GED/Diploma	
Total							0

Total Adult Ed Participants this Submission

July Participants for Fall 2023-2024	0
September Participants for Fall 2023-2024	0
Total Adult Education Count for Fall 2023-2024	0

Summary of Membership

Total Special Education	26.70
Subtract: Non Resident Special Education without Release Form	0.00
Total Adjusted Special Education Count	26.70
K-12 Pupils	1,156.36
Subtract: Non Resident General Education without Release Form	0.00
Total Adjusted K-12 Membership Count	1,156.36
Total Adjusted K-12 & Special Education FTE	1,183.06

Section 25 Net Adjustments

Special Education Section 25 Adjustments	-0.57
General Education Section 25 Adjustments	0.13
Total Section 25 Adjustments	-0.44